

**This electronic collection of documents is provided
for the convenience of the user
and is Not a Certified Document –**

**The documents contained herein were originally issued
and sealed by the individuals whose names and license
numbers appear on each page, on the dates appearing
with their signature on that page.**

**This file or an individual page
shall not be considered a certified document.**

09.08/2019

TIP PROJECT: I-5964

CONTRACT: DG00491

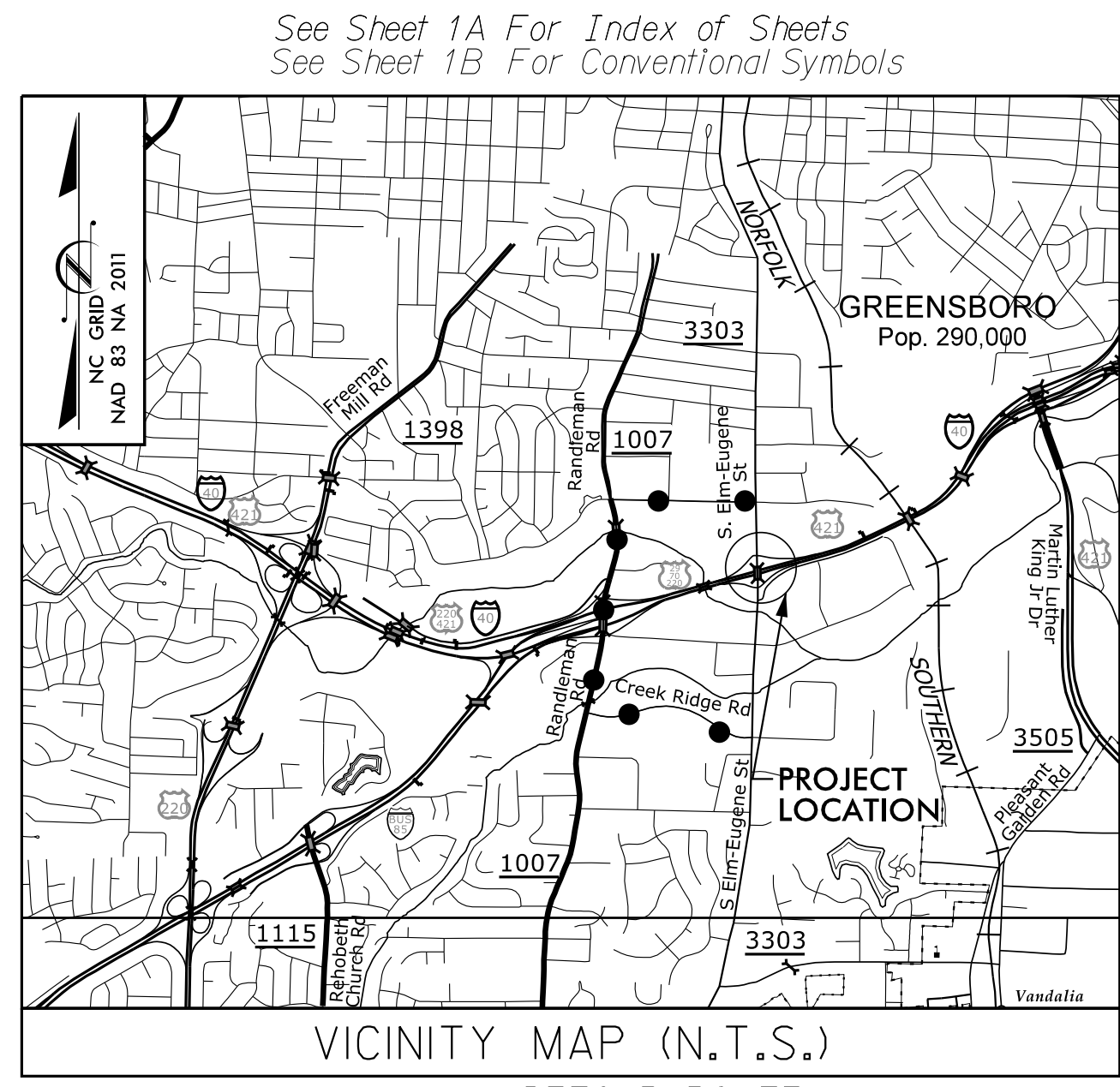

STATE OF NORTH CAROLINA
DIVISION OF HIGHWAYS
GUILFORD COUNTY

LOCATION: I-40/I-85 BUS./SOUTH ELM-EUGENE INTERCHANGE IMPROVEMENTS

TYPE OF WORK: GRADING, DRAINAGE, PAVING, AND SIGNALS

STATE	STATE PROJECT REFERENCE NO.	SHEET NO.	TOTAL SHEETS
N.C.	I-5964	1	
STATE PROJ. NO.	F.A. PROJ. NO.	DESCRIPTION	
45914.1.1	NA	PE	
45914.2.1	NA	RW & UTILITIES	
45914.3.2	0040109	CONST.	

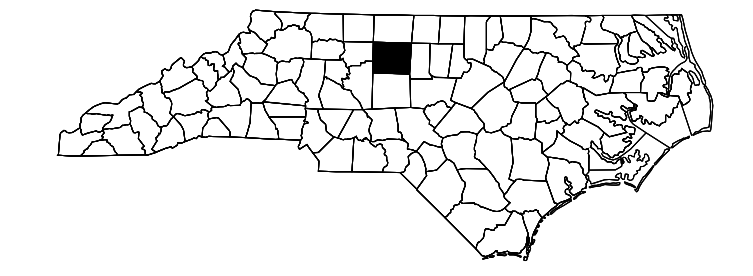

V&M
Vaughn & Melton
Consulting Engineers

Charlotte, North Carolina 704-357-0488
Tri-Cities, Tennessee 423-467-8400
Knoxville, Tennessee 865-546-5800
Middlesboro, Kentucky 606-248-6600
Spartanburg, South Carolina 864-534-4775

Copyright © 1994 Vaughn & Melton, Inc. All Rights Reserved.

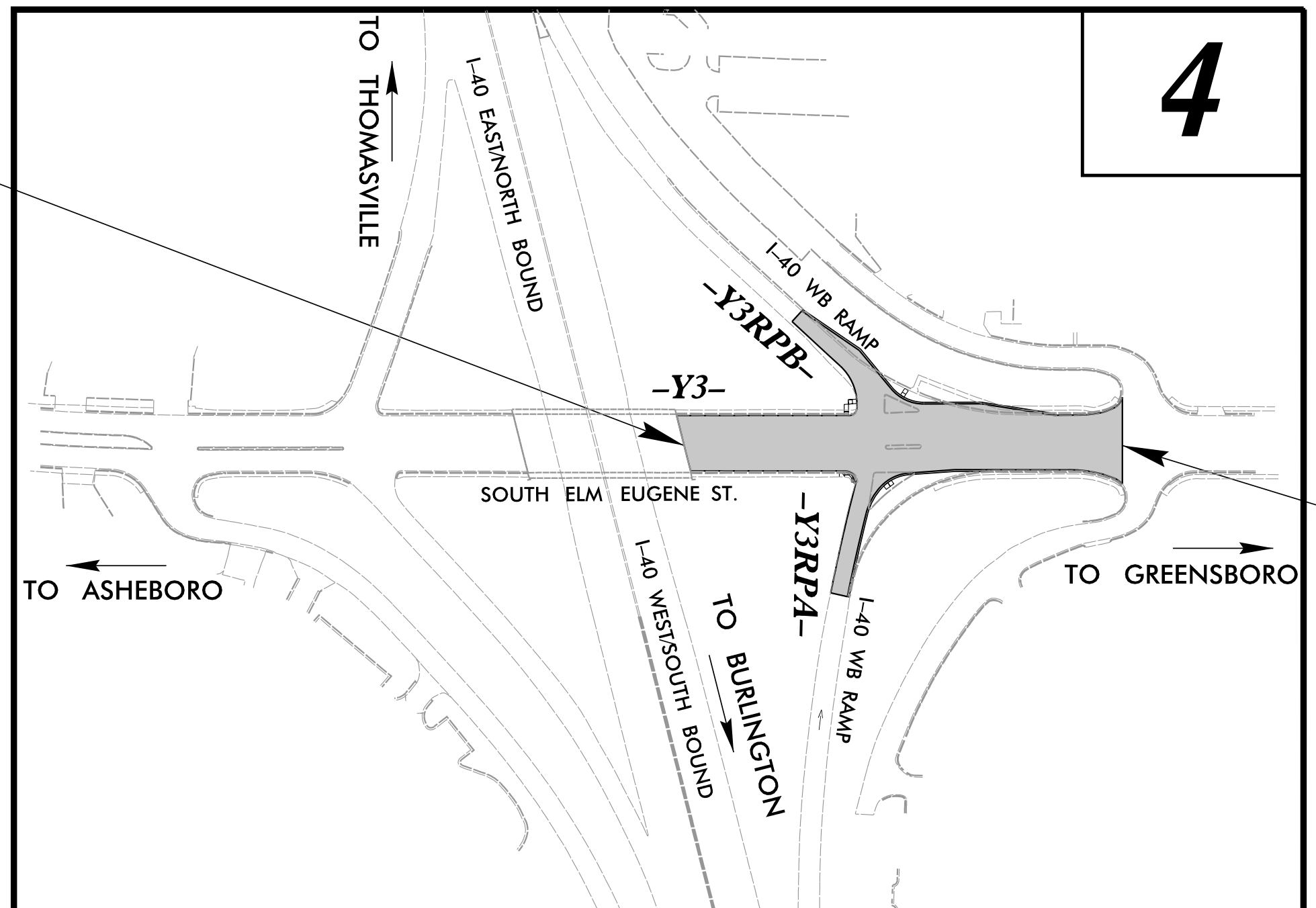

BEGIN TIP PROJECT I-5964
-Y3- STA. 13 + 90.40

END TIP PROJECT I-5964
-Y3- STA. 19 + 00.00



FINAL 100% ROADWAY PLANS

DOCUMENT NOT CONSIDERED FINAL UNLESS ALL SIGNATURES COMPLETED

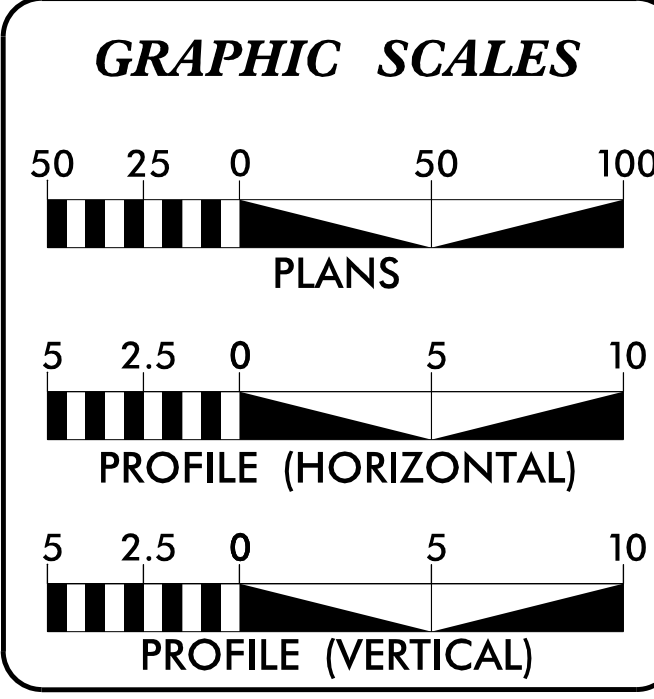

DESIGN DATA
ADT 2018 = 27,000
ADT 2045 = 29,000
D = 55%
K = 10%
T = 3%
*TTST = 1% DUAL = 2%
FUNCT. CLASS = MINOR ARTERIAL
STATEWIDE TIER

PROJECT LENGTH
LENGTH ROADWAY TIP PROJECT I-5964 = .097 MI
TOTAL LENGTH OF TIP PROJECT I-5964 = .097 MI

Prepared in the Office of:
VAUGHN & MELTON
1318-F PATTON AVE.
ASHEVILLE NC, 28806
FOR THE NORTH CAROLINA DIVISION OF HIGHWAYS

2018 STANDARD SPECIFICATIONS

RIGHT OF WAY DATE:

LETTING DATE:
8/5/2021

REECE SCHULER, PE
PROJECT ENGINEER

JOHN LANSFORD, PE
PROJECT DESIGN ENGINEER

BRIAN KETNER, PE
NCDOT CONTACT

HYDRAULICS ENGINEER

DocuSigned by:
Bradley Kidner
7/12/2021 10:54:54 AM
SIGNATURE: [Signature]

ROADWAY DESIGN ENGINEER

DocuSigned by:
John Lansford
7/12/2021 10:54:54 AM
SIGNATURE: [Signature]

Professional Engineer Seals for Bradley Kidner and John Lansford.

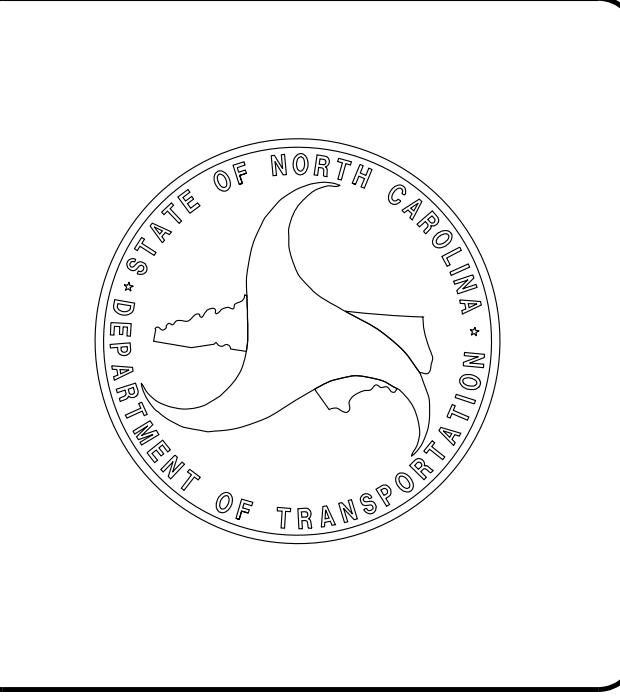

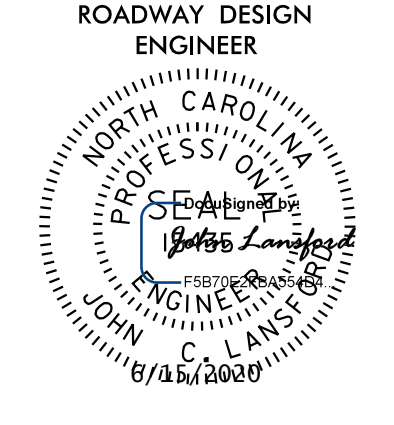
PROJECT REFERENCE NO.	SHEET NO.
I-5964	1A
	
DOCUMENT NOT CONSIDERED FINAL UNLESS ALL SIGNATURES COMPLETED	

8/17/19
6/10/2020
I:\Northville\transportation\31639-03 I-5964 Div 7 I-40 Elm-Eugene\Roadway\Proj\31639-rdy-1A.dgn

SHEET NUMBER	INDEX OF SHEETS SHEET
1	TITLE SHEET
1A	INDEX OF SHEETS, GENERAL NOTES, AND LIST OF STANDARD DRAWINGS
1B	CONVENTIONAL SYMBOLS
2A-1 THRU 2A-2	PAVEMENT SCHEDULE, TYPICAL SECTIONS, WEDGING DETAILS
2B-1	SPECIAL RAMP DETAIL
3B-1	EARTHWORK AND PAVEMENT REMOVAL
3D-1	DRAINAGE SUMMARY
4	PLAN SHEET
5	PROFILE SHEET
RW-01 THRU RW02C-3	SURVEY CONTROL SHEETS
TMP-1 THRU TMP-5	TRAFFIC MANAGEMENT PLANS
PMP-1 THRU PMP-2	PAVEMENT MARKING PLANS
EC-1 THRU EC-5	EROSION CONTROL PLANS
SIGN-1 THRU SIGN-3	SIGNING PLANS
SIG.1 THRU SIG.5.1	SIGNAL PLANS
SIG.M1 THRU SIG.M8	STANDARD DRAWINGS FOR METAL POLES
X-1A	CROSS-SECTION SUMMARY SHEET
X-1 THRU X-6	CROSS-SECTIONS

GENERAL NOTES:

2018 SPECIFICATIONS
EFFECTIVE: 01-16-2018

2018 ROADWAY ENGLISH STANDARD DRAWINGS

The following Roadway Standards as appear in "Roadway Standard Drawings" Highway Design Branch - N. C. Department of Transportation - Raleigh, N. C., Dated January 16, 2018 are applicable to this project and by reference hereby are considered a part of these plans:

STD.NO.	TITLE
DIVISION 2 - EARTHWORK	
225.02	Guide for Grading Subgrade - Secondary and Local
225.04	Method of Obtaining Superelevation - Two Lane Pavement
DIVISION 3 - PIPE CULVERTS	
300.01	Method of Pipe Installation
DIVISION 5 - SUBGRADE, BASES AND SHOULDERS	
560.01	Method of Shoulder Construction - High Side of Superelevated Curve - Method I
DIVISION 6 - ASPHALT BASES AND PAVEMENTS	
654.01	Pavement Repair
DIVISION 8 - INCIDENTALS	
806.01	Concrete Right-of-Way Marker
806.02	Granite Right-of-Way Marker
840.00	Concrete Base Pad for Drainage Structure
840.01	Brick Catch Basin - 12" thru 54" Pipe
840.02	Concrete Catch Basin - 12" thru 54" Pipe
840.03	Frame, Grates and Hood - for Use on Standard Catch Basin
840.45	Precast Drainage Structure
840.72	Pipe Collar
846.01	Concrete Curb, Gutter and Curb & Gutter
848.01	Concrete Sidewalk
866.01	Chain Link Fence - 5' High Fence

GRADE LINE:
GRADING AND SURFACING OR RESURFACING AND WIDENING:

THE GRADE LINES SHOWN DENOTE THE FINISHED ELEVATION OF THE PROPOSED SURFACING AT GRADE POINTS SHOWN ON THE TYPICAL SECTIONS. WHERE NO GRADE LINES ARE SHOWN, THE PROFILES SHOWN DENOTE THE TOP ELEVATION OF THE EXISTING PAVEMENT ALONG THE CENTER LINE OF SURVEY ON WHICH THE PROPOSED RESURFACING WILL BE PLACED. GRADE LINES MAY BE ADJUSTED BY THE ENGINEER IN ORDER TO SECURE A PROPER TIE-IN.

CLEARING:
CLEARING ON THIS PROJECT SHALL BE PERFORMED TO THE LIMITS ESTABLISHED BY METHOD II.

SHOULDER CONSTRUCTION:
ASPHALT, EARTH, AND CONCRETE SHOULDER CONSTRUCTION ON THE HIGH SIDE OF SUPERELEVATED CURVES SHALL BE IN ACCORDANCE WITH STD. NO. 560.01.

SUBSURFACE PLANS:
NO SUBSURFACE PLANS ARE AVAILABLE ON THIS PROJECT. THE CONTRACTOR SHOULD MAKE HIS OWN INVESTIGATION AS TO THE SUBSURFACE CONDITIONS.

UTILITIES:
UTILITY OWNERS ON THIS PROJECT ARE: FRONTIER COMMUNICATIONS AND DUKE ENERGY.
ANY RELOCATION OF EXISTING UTILITIES WILL BE ACCOMPLISHED BY OTHERS.

RIGHT-OF-WAY MARKERS:
ALL RIGHT-OF-WAY MARKERS ON THIS PROJECT SHALL BE PLACED BY CONTRACT IN ACCORDANCE WITH SECTION 801 OF THE 2018 NORTH CAROLINA STANDARD SPECIFICATIONS FOR ROADS AND STRUCTURES.

CURB RAMPS:
CURB RAMPS ARE SHOWN ON THE PLANS AT APPROXIMATE LOCATIONS.
CONSTRUCT ALL CURB RAMPS IN ACCORDANCE WITH STD 848.05 and/or 848.06 and/or SPECIAL DETAILS ON SHEET 2B-1.

TEMPORARY SHORING:
SHORING REQUIRED FOR THE MAINTENANCE OF TRAFFIC WILL BE PAID FOR AS "EXTRA WORK" IN ACCORDANCE WITH SECTION 104-7.

STATE OF NORTH CAROLINA, DIVISION OF HIGHWAYS

CONVENTIONAL PLAN SHEET SYMBOLS

BOUNDARIES AND PROPERTY:

State Line	-----
County Line	-----
Township Line	-----
City Line	-----
Reservation Line	-----
Property Line	-----
Existing Iron Pin	○ EIP
Computed Property Corner	-----x
Property Monument	□ ECM
Parcel/Sequence Number	⑩②③
Existing Fence Line	-x-x-x-x-
Proposed Woven Wire Fence	○
Proposed Chain Link Fence	□
Proposed Barbed Wire Fence	◇
Existing Wetland Boundary	---WLB---
Proposed Wetland Boundary	---WLB---
Existing Endangered Animal Boundary	---EAB---
Existing Endangered Plant Boundary	---EPB---
Existing Historic Property Boundary	---HPB---
Known Contamination Area: Soil	☠-S-☠
Potential Contamination Area: Soil	☠-S-☠
Known Contamination Area: Water	☠-W-☠
Potential Contamination Area: Water	☠-W-☠
Contaminated Site: Known or Potential	☠?

BUILDINGS AND OTHER CULTURE:

Gas Pump Vent or U/G Tank Cap	○
Sign	○ S
Well	○ W
Small Mine	✕
Foundation	□
Area Outline	□
Cemetery	□
Building	□
School	□
Church	□
Dam	▬

HYDROLOGY:

Stream or Body of Water	-----
Hydro, Pool or Reservoir	-----
Jurisdictional Stream	---JS---
Buffer Zone 1	---BZ 1---
Buffer Zone 2	---BZ 2---
Flow Arrow	←
Disappearing Stream	→
Spring	○
Wetland	---WLB---
Proposed Lateral, Tail, Head Ditch	---FLOW---
False Sump	▽

RAILROADS:

Standard Gauge	-----
RR Signal Milepost	○ CSX TRANSPORTATION MILEPOST 35
Switch	□ SWITCH
RR Abandoned	-----
RR Dismantled	-----

Note: Not to Scale *S.U.E. = *Subsurface Utility Engineering*

RIGHT OF WAY & PROJECT CONTROL:

Secondary Horiz and Vert Control Point	◆
Primary Horiz Control Point	○
Primary Horiz and Vert Control Point	●
Exist Permanent Easment Pin and Cap	◇
New Permanent Easement Pin and Cap	◆
Vertical Benchmark	⊠
Existing Right of Way Marker	△
Existing Right of Way Line	-----
New Right of Way Line	-----
New Right of Way Line with Pin and Cap	-----
New Right of Way Line with Concrete or Granite R/W Marker	-----
New Control of Access Line with Concrete CA Marker	-----
Existing Control of Access	-----
New Control of Access	-----
Existing Easement Line	-----
New Temporary Construction Easement	-----
New Temporary Drainage Easement	-----
New Permanent Drainage Easement	-----
New Permanent Drainage / Utility Easement	-----
New Permanent Utility Easement	-----
New Temporary Utility Easement	-----
New Aerial Utility Easement	-----

ROADS AND RELATED FEATURES:

Existing Edge of Pavement	-----
Existing Curb	-----
Proposed Slope Stakes Cut	---C---
Proposed Slope Stakes Fill	---F---
Proposed Curb Ramp	---CR---
Existing Metal Guardrail	-----
Proposed Guardrail	-----
Existing Cable Guiderail	-----
Proposed Cable Guiderail	-----
Equality Symbol	⊕
Pavement Removal	-----

VEGETATION:

Single Tree	☼
Single Shrub	☼

Hedge	-----
Woods Line	-----
Orchard	-----
Vineyard	-----

EXISTING STRUCTURES:

MAJOR:	
Bridge, Tunnel or Box Culvert	-----
Bridge Wing Wall, Head Wall and End Wall	-----
MINOR:	
Head and End Wall	-----
Pipe Culvert	-----
Footbridge	-----
Drainage Box: Catch Basin, DI or JB	-----
Paved Ditch Gutter	-----
Storm Sewer Manhole	-----
Storm Sewer	-----

UTILITIES:

POWER:	
Existing Power Pole	●
Proposed Power Pole	○
Existing Joint Use Pole	●
Proposed Joint Use Pole	○
Power Manhole	⊕
Power Line Tower	⊠
Power Transformer	⊠
U/G Power Cable Hand Hole	-----
H-Frame Pole	●
U/G Power Line LOS B (S.U.E.*)	-----
U/G Power Line LOS C (S.U.E.*)	-----
U/G Power Line LOS D (S.U.E.*)	-----

TELEPHONE:

Existing Telephone Pole	●
Proposed Telephone Pole	○
Telephone Manhole	⊕
Telephone Pedestal	⊠
Telephone Cell Tower	⊠
U/G Telephone Cable Hand Hole	-----
U/G Telephone Cable LOS B (S.U.E.*)	-----
U/G Telephone Cable LOS C (S.U.E.*)	-----
U/G Telephone Cable LOS D (S.U.E.*)	-----
U/G Telephone Conduit LOS B (S.U.E.*)	-----
U/G Telephone Conduit LOS C (S.U.E.*)	-----
U/G Telephone Conduit LOS D (S.U.E.*)	-----
U/G Fiber Optics Cable LOS B (S.U.E.*)	-----
U/G Fiber Optics Cable LOS C (S.U.E.*)	-----
U/G Fiber Optics Cable LOS D (S.U.E.*)	-----

WATER:

Water Manhole	⊕
Water Meter	○
Water Valve	⊗
Water Hydrant	⊕
U/G Water Line LOS B (S.U.E.*)	-----
U/G Water Line LOS C (S.U.E.*)	-----
U/G Water Line LOS D (S.U.E.*)	-----
Above Ground Water Line	-----

TV:

TV Pedestal	⊠
TV Tower	⊗
U/G TV Cable Hand Hole	-----
U/G TV Cable LOS B (S.U.E.*)	-----
U/G TV Cable LOS C (S.U.E.*)	-----
U/G TV Cable LOS D (S.U.E.*)	-----
U/G Fiber Optic Cable LOS B (S.U.E.*)	-----
U/G Fiber Optic Cable LOS C (S.U.E.*)	-----
U/G Fiber Optic Cable LOS D (S.U.E.*)	-----

GAS:

Gas Valve	◇
Gas Meter	⊕
U/G Gas Line LOS B (S.U.E.*)	-----
U/G Gas Line LOS C (S.U.E.*)	-----
U/G Gas Line LOS D (S.U.E.*)	-----
Above Ground Gas Line	-----

SANITARY SEWER:

Sanitary Sewer Manhole	⊕
Sanitary Sewer Cleanout	⊕
U/G Sanitary Sewer Line	-----
Above Ground Sanitary Sewer	-----
SS Forced Main Line LOS B (S.U.E.*)	-----
SS Forced Main Line LOS C (S.U.E.*)	-----
SS Forced Main Line LOS D (S.U.E.*)	-----

MISCELLANEOUS:

Utility Pole	●
Utility Pole with Base	□
Utility Located Object	○
Utility Traffic Signal Box	⊠
Utility Unknown U/G Line LOS B (S.U.E.*)	-----
U/G Tank; Water, Gas, Oil	-----
Underground Storage Tank, Approx. Loc.	-----
A/G Tank; Water, Gas, Oil	-----
Geoenvironmental Boring	⊕
U/G Test Hole LOS A (S.U.E.*)	-----
Abandoned According to Utility Records	AATUR
End of Information	E.O.I.

5/14/99

V&M
Vaughn & Melton
 Consulting Engineers

Asheville, North Carolina
 828-293-2796

Boone, NC 828-255-9933
 Tryonville, NC 828-293-2796
 Raleigh, NC 919-977-9455

Chapel Hill, NC 919-977-9455
 Charlotte, NC 704-351-0488
 Knoxville, TN 865-546-5000
 Spartanburg, SC 864-574-4775
 Charleston, SC 843-974-5650
 Mississippi, KY 606-248-6600
 Atlanta, GA 770-627-3509

Copyright © 2005 Vaughn & Melton, Inc. All Rights Reserved

PROJECT REFERENCE NO. <i>1-5964</i>	SHEET NO. <i>2A-1</i>
RW SHEET NO.	
ROADWAY DESIGN ENGINEER	PAVEMENT ENGINEER
DOCUMENT NOT CONSIDERED FINAL UNLESS ALL SIGNATURES COMPLETED	

PAVEMENT SCHEDULE			
<i>(FINAL PAVEMENT DESIGN)</i>			
C1	PROP. APPROX. 1 1/2" ASPHALT CONCRETE SURFACE COURSE, TYPE S9.5C, AT AN AVERAGE RATE OF 168 LBS. PER SQ. YD.	S	CONCRETE SIDEWALK
C2	PROP. APPROX. 3" ASPHALT CONCRETE SURFACE COURSE, TYPE S9.5C, AT AN AVERAGE RATE OF 168 LBS. PER SQ. YD. IN EACH OF TWO LAYERS.	T	EARTH MATERIAL.
D1	PROP. APPROX. 4" ASPHALT CONCRETE INTERMEDIATE COURSE, TYPE I19.0C, AT AN AVERAGE RATE OF 456 LBS. PER SQ. YD.	U	EXISTING PAVEMENT.
E1	PROP. APPROX. 4" ASPHALT CONCRETE BASE COURSE, TYPE B25.0C, AT AN AVERAGE RATE OF 456 LBS. PER SQ. YD.	V	MILLING ASPHALT PAVEMENT, 1-1/2" DEPTH
R1	2'-6" CONCRETE CURB AND GUTTER.		

NOTE: PAVEMENT EDGE SLOPES ARE 1:1 UNLESS SHOWN OTHERWISE.

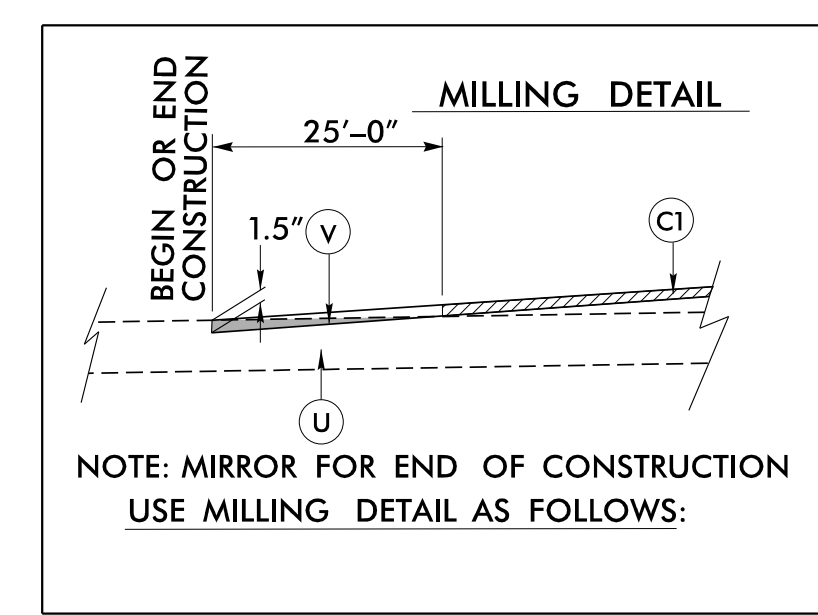

6/11/2016 10:59:42 PM P:\31639_rdy_tjpr.dgn

5/14/09

PAVEMENT SCHEDULE	
C1	1 1/2" S9.5C
C2	3" S9.5C
D1	4" I19.0C
E1	4" B25.0C
R1	2'-6" CONCRETE CURB AND GUTTER
S	5' CONC. SIDEWALK
T	EARTH MATERIAL
U	EXISTING PAVEMENT
V	1-1/2" MILLING

V&M
Vaughn & Melton
 Consulting Engineers
 Asheville, North Carolina
 828-253-9796

Boone, NC 828-355-9333
 1-1-CHESA, TN 423-467-8400
 Knoxville, TN 865-546-5800
 Spartanburg, SC 864-574-4775
 Charleston, SC 843-974-5650
 Mississippi, KY 606-248-6600
 Charlotte, NC 704-357-0488
 Atlanta, GA 770-427-2029

Copyright © 2006 Vaughn & Melton, Inc. All Rights Reserved.

PROJECT REFERENCE NO. 1-5964	SHEET NO. 2A-2
ROADWAY DESIGN ENGINEER	PAVEMENT ENGINEER
<i>[Signature]</i> 6/17/2009	<i>[Signature]</i> 6/17/2009
DOCUMENT NOT CONSIDERED FINAL UNLESS ALL SIGNATURES COMPLETED	

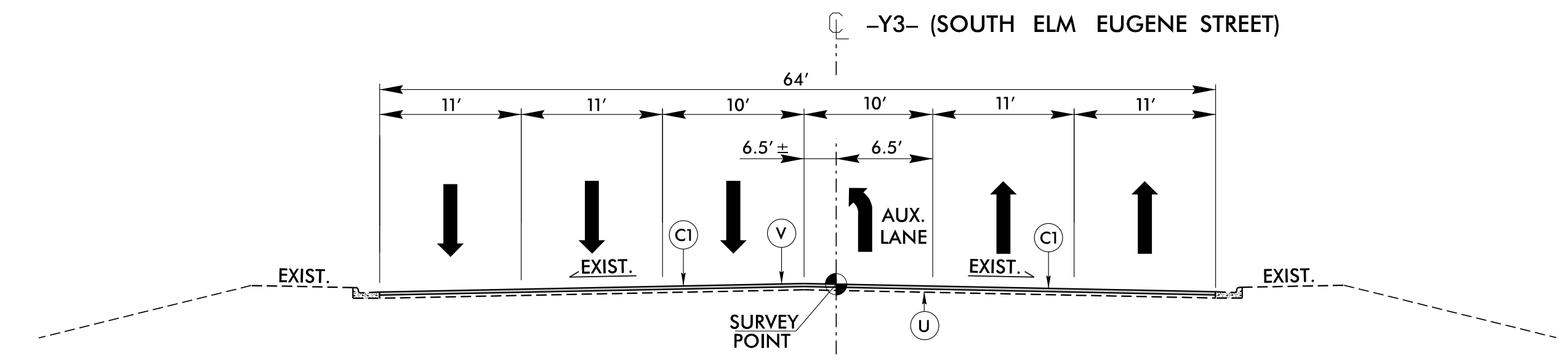

TYPICAL SECTION NO. 1
 -Y3- STA. 13+90.40 TO STA. 16+01.45
 -Y3- STA. 18+20.40 TO STA. 19+00.00

NOTE: SEE PLANS FOR TURN LANES, AUXILIARY LANES AND RAMP LANES.

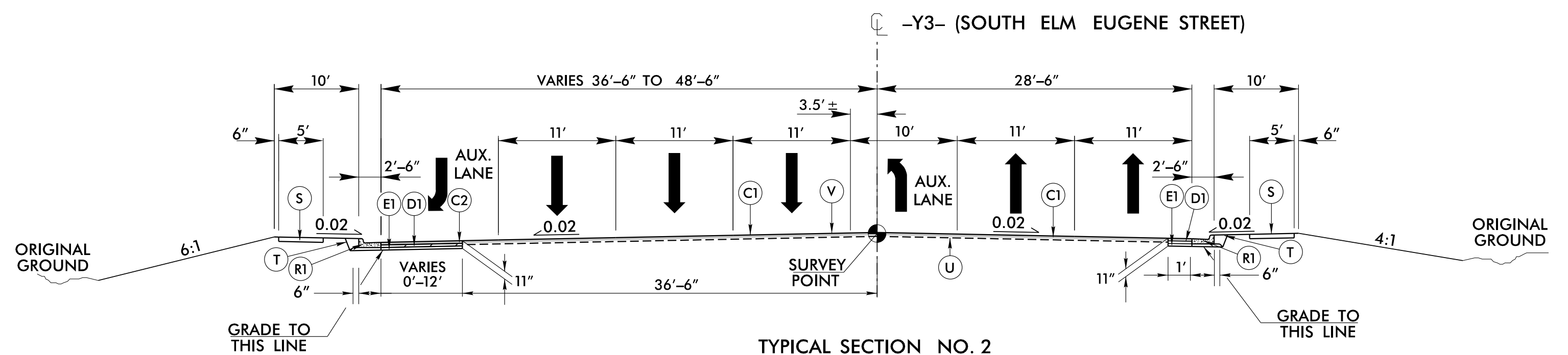

TYPICAL SECTION NO. 2
 -Y3- STA. 16+01.45 TO STA. 18+20.40

NOTE: SEE PLANS FOR TURN LANES, AUXILIARY LANES AND RAMP LANES.

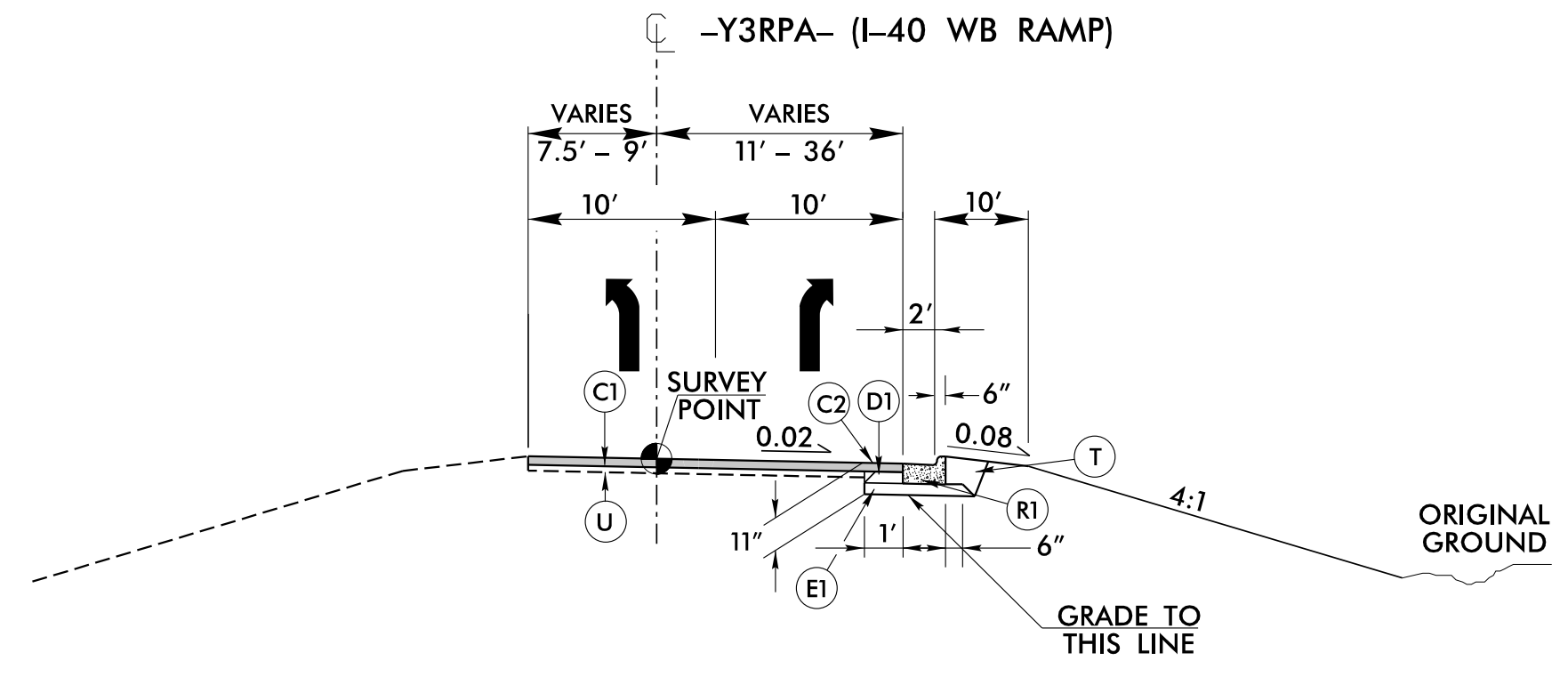

TYPICAL SECTION NO. 3
 -Y3RPA- STA. 18+56 TO STA. 20+04.29

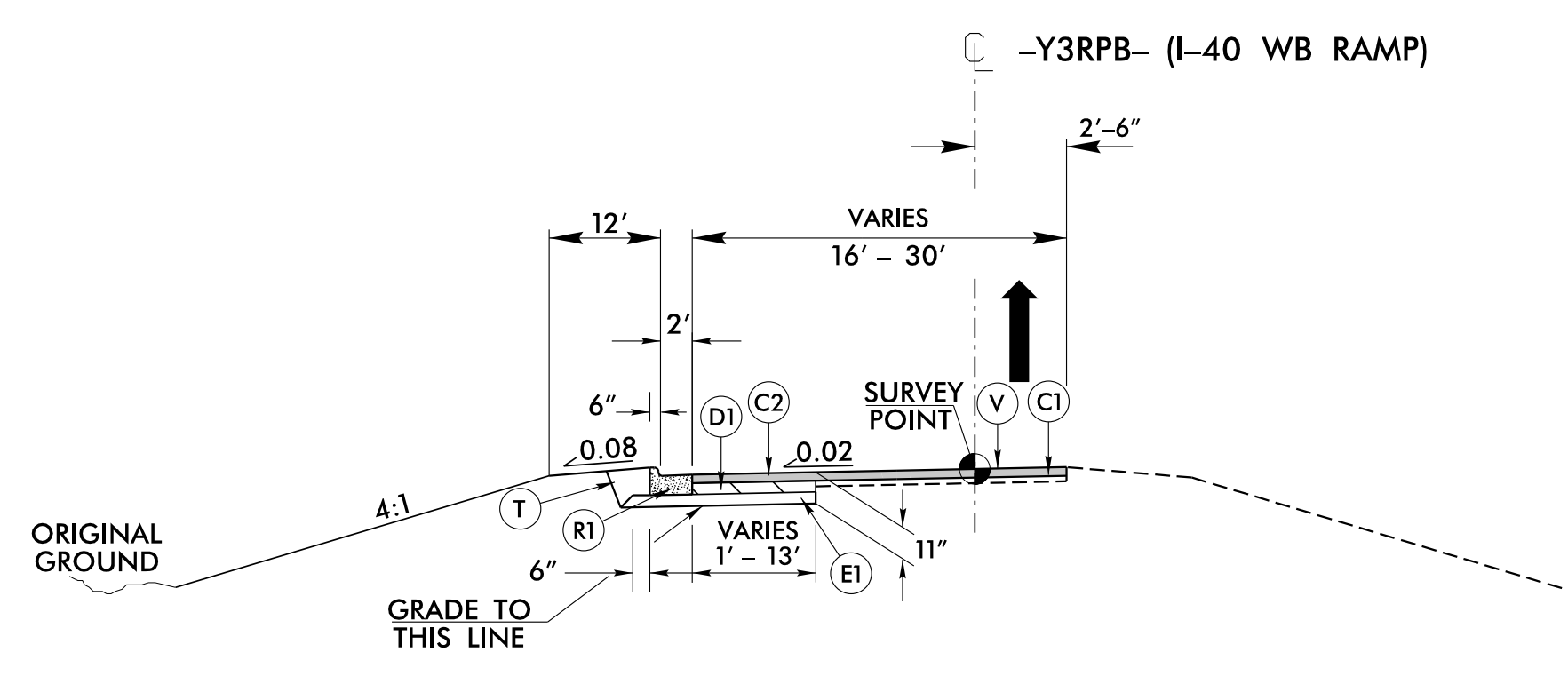

TYPICAL SECTION NO. 4
 -Y3RPB- STA. 16+65 TO STA. 18+09.68

6/11/2009 10:59:42 PM P:\0316339_rdy_tjpr.dgn

PAY LIMITS FOR 1 CURB RAMP

V&M
Vaughan & Melton
Consulting Engineers

Asheville, NC
North Carolina
828 253-2796

Raleigh, NC
919-977-3955

Boone, NC
828-255-1933

Tri-City, TN
423-487-1800

Knoxville, TN
865-548-5800

Spartanburg, SC
864-574-4715

Cherokee, SC
863-574-5600

Madison, AL
806-249-6600

Atlanta, GA
770-397-0488

770-627-3509

Copyright © 2006, Vaughan & Melton, Inc. All Rights Reserved.

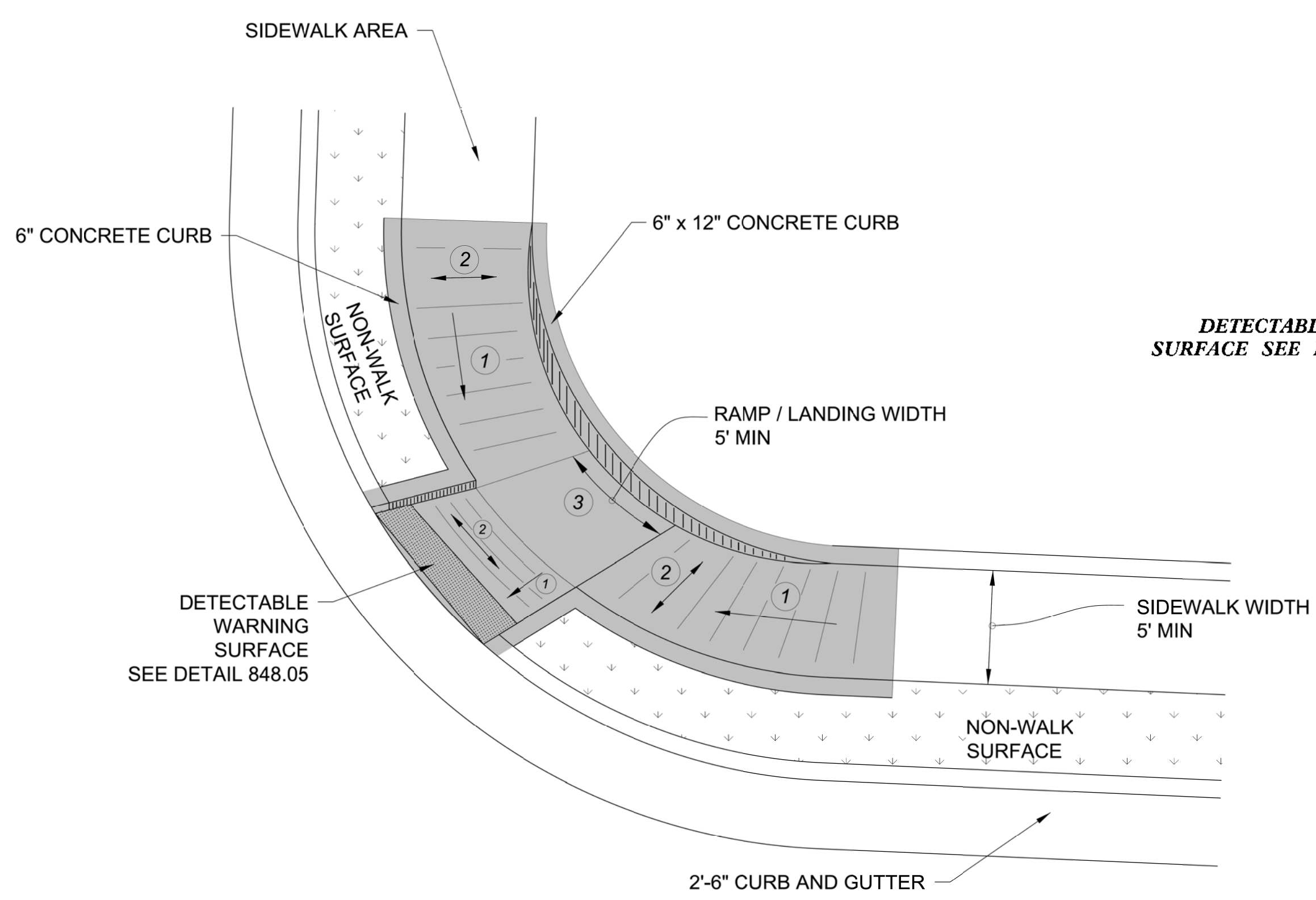

TYPE 3 MODIFIED
INSTALLATION IN A RADIUS

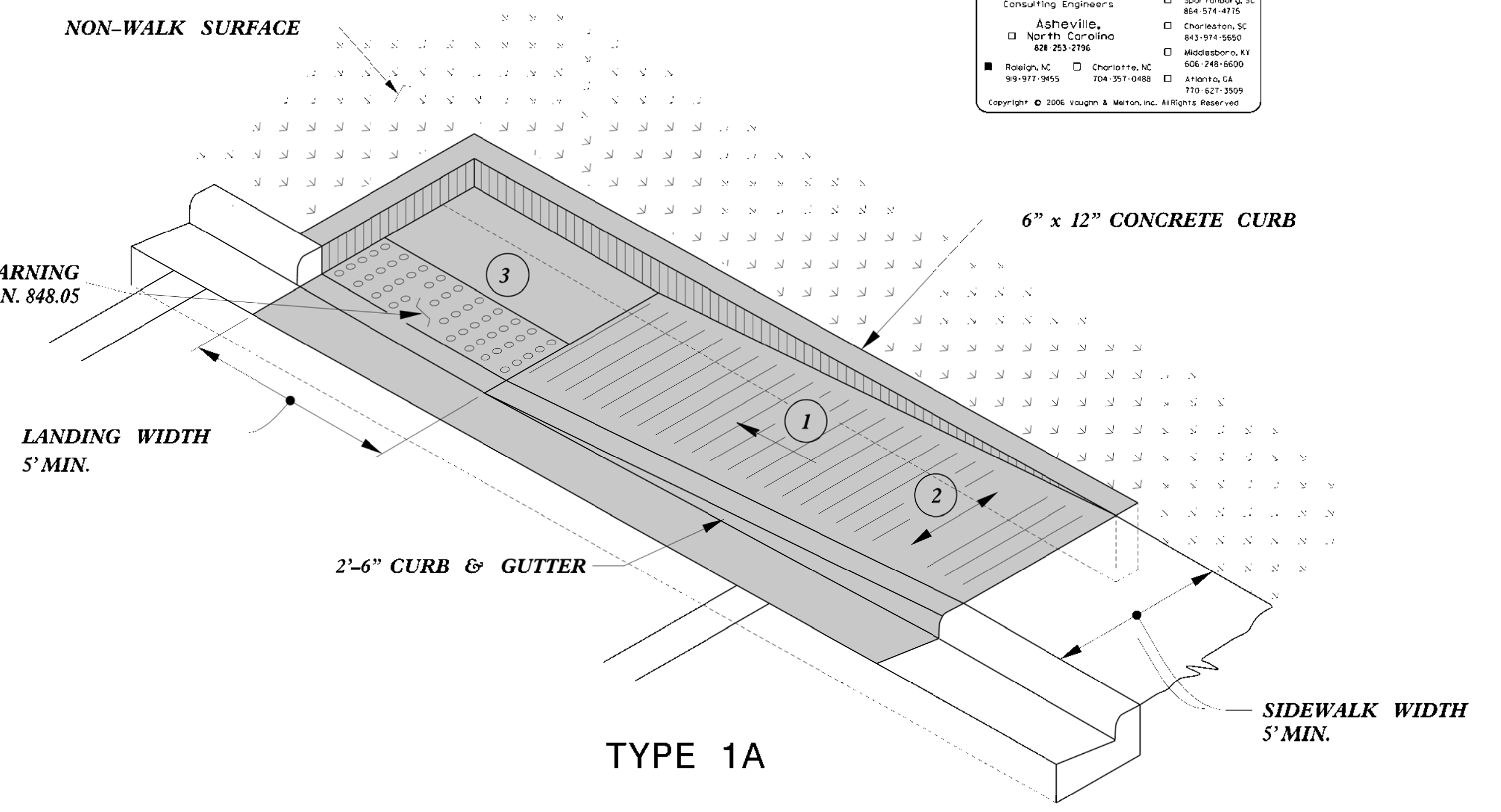

TYPE 1A

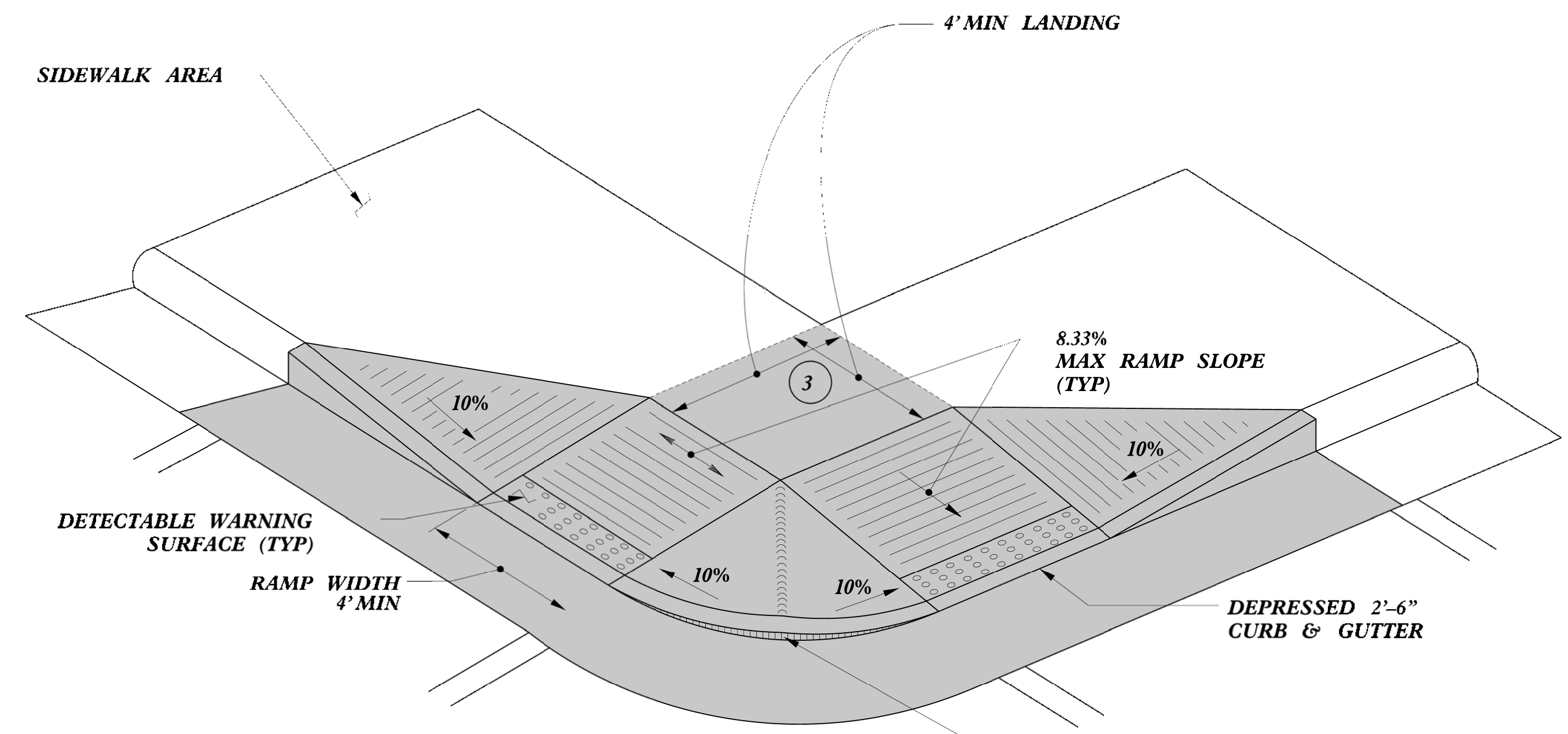

TYPE 4

- 1 8.33% (12:1) MAX RAMP SLOPE
- 2 CROSS SLOPE: 2.00%
- 3 CURB RAMPS REQUIRE A (4'-0") MINIMUM LANDING WITH A MAXIMUM CROSS SLOPE AND LONGITUDINAL SLOPE OF 2.00% WHERE PEDESTRIANS PERFORM TURNING MANEUVERS. SLOPE TO DRAIN TO CURB.

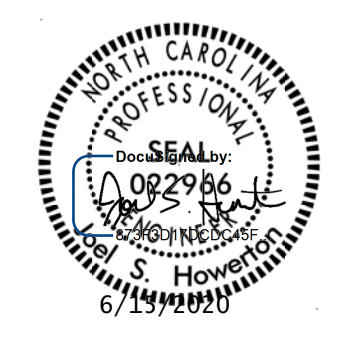

DOCUMENT NOT CONSIDERED FINAL
UNLESS ALL SIGNATURES COMPLETED

**CONTRACT STANDARDS
AND DEVELOPMENT UNIT**
Office 919-707-6950 FAX 919-250-4119

CURB RAMPS

ORIGINAL BY: J.S. HOWERTON DATE: 7/7/11
 MODIFIED BY: _____ DATE: _____
 CHECKED BY: _____ DATE: _____
 FILE SPEC.: stds/2012CurbRamp/CurbRampDetails.dgn

6/6/2010 10:45:25 AM P:\Projects\2012\2012-CurbRamp\2012-CurbRamp.dgn

5/14/99

PROJECT REFERENCE NO. 1-5964		SHEET NO. 4	
ROADWAY DESIGN ENGINEER		HYDRAULICS ENGINEER	
DOCUMENT NOT CONSIDERED FINAL UNLESS ALL SIGNATURES COMPLETED			

Asheville, NC
North Carolina
828.253.2726

Asheville, NC 828.253.2726
Charlotte, NC 704.357.0488
Atlanta, GA 770.627.3509

Copyright © 2006 Vaughn & Melton, Inc. All Rights Reserved

-Y3RPB-
 PI Sta 12+82.86
 $\Delta = 33^{\circ}00'00.0''$ (LT)
 $D = 6^{\circ}00'00.0''$
 $L = 550.00'$
 $T = 282.86'$
 $R = 954.93'$

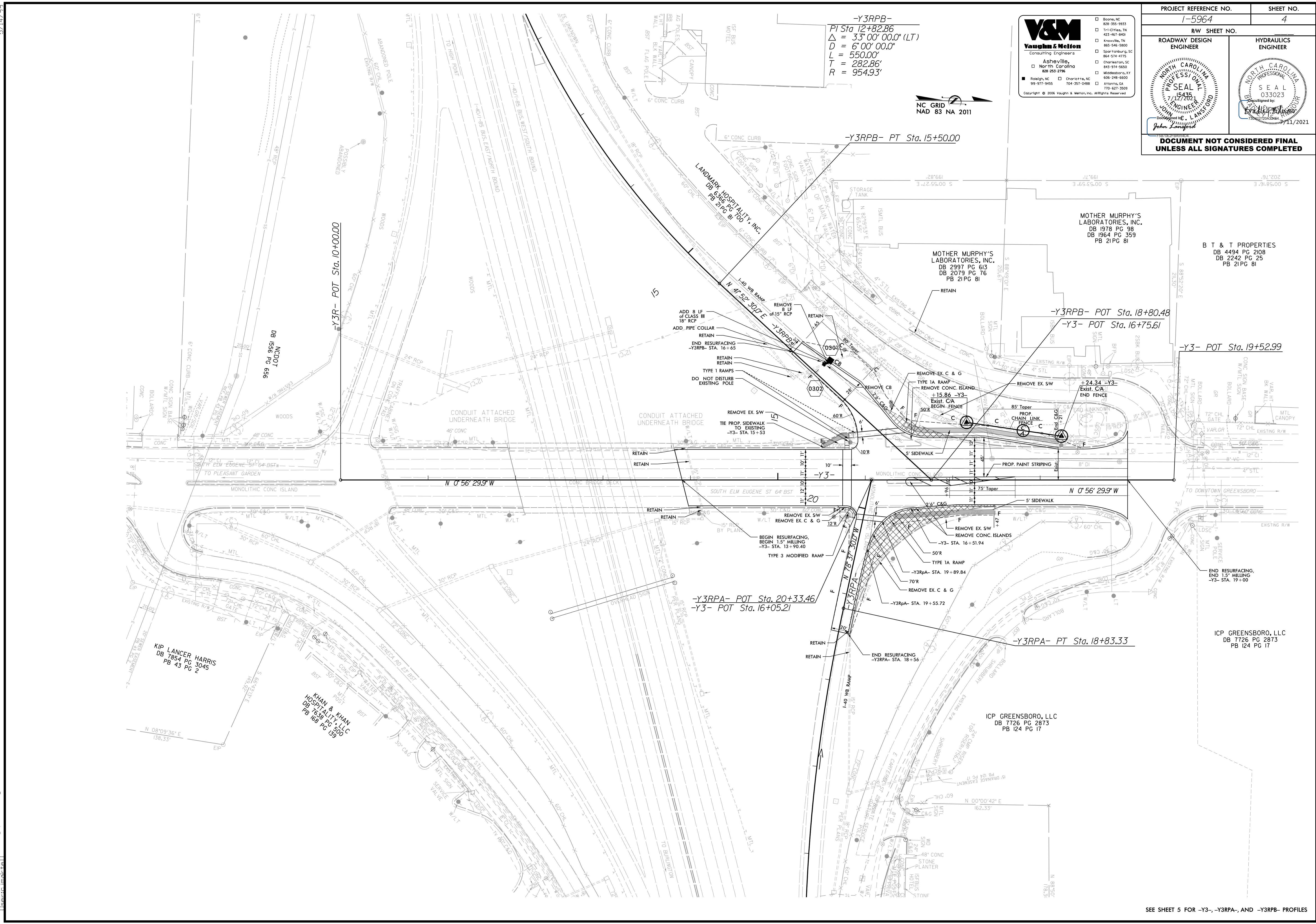

7/8/2023 11:53 AM rdy_psh_04.dgn

5/28/19

PROJECT REFERENCE NO. 1-5964	SHEET NO. 5
ROADWAY DESIGN ENGINEER <i>John Blumfeld</i> 6/25/2020	HYDRAULICS ENGINEER <i>SEAN S. EDWARDS</i> 6/25/2020

DOCUMENT NOT CONSIDERED FINAL
UNLESS ALL SIGNATURES COMPLETED

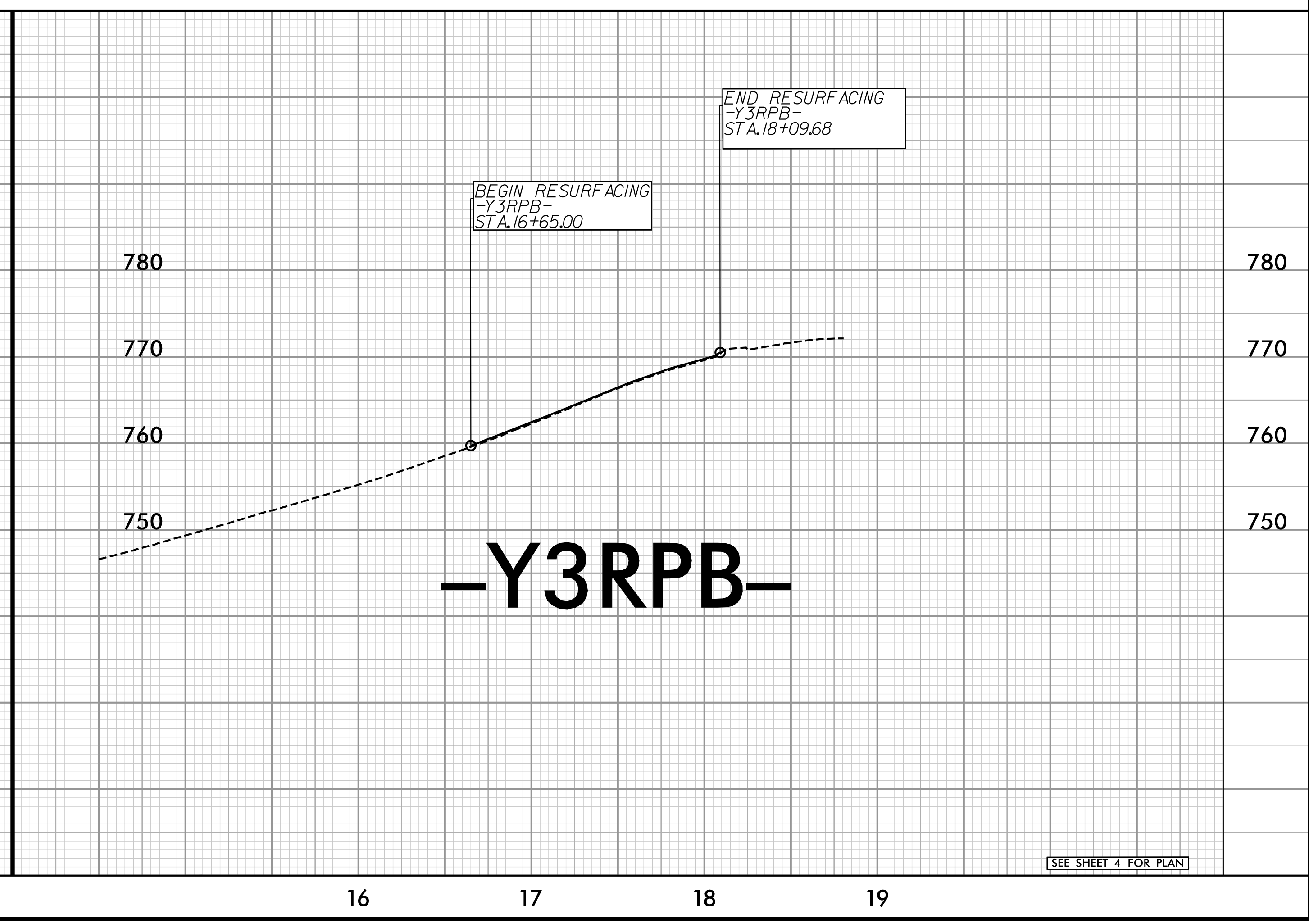
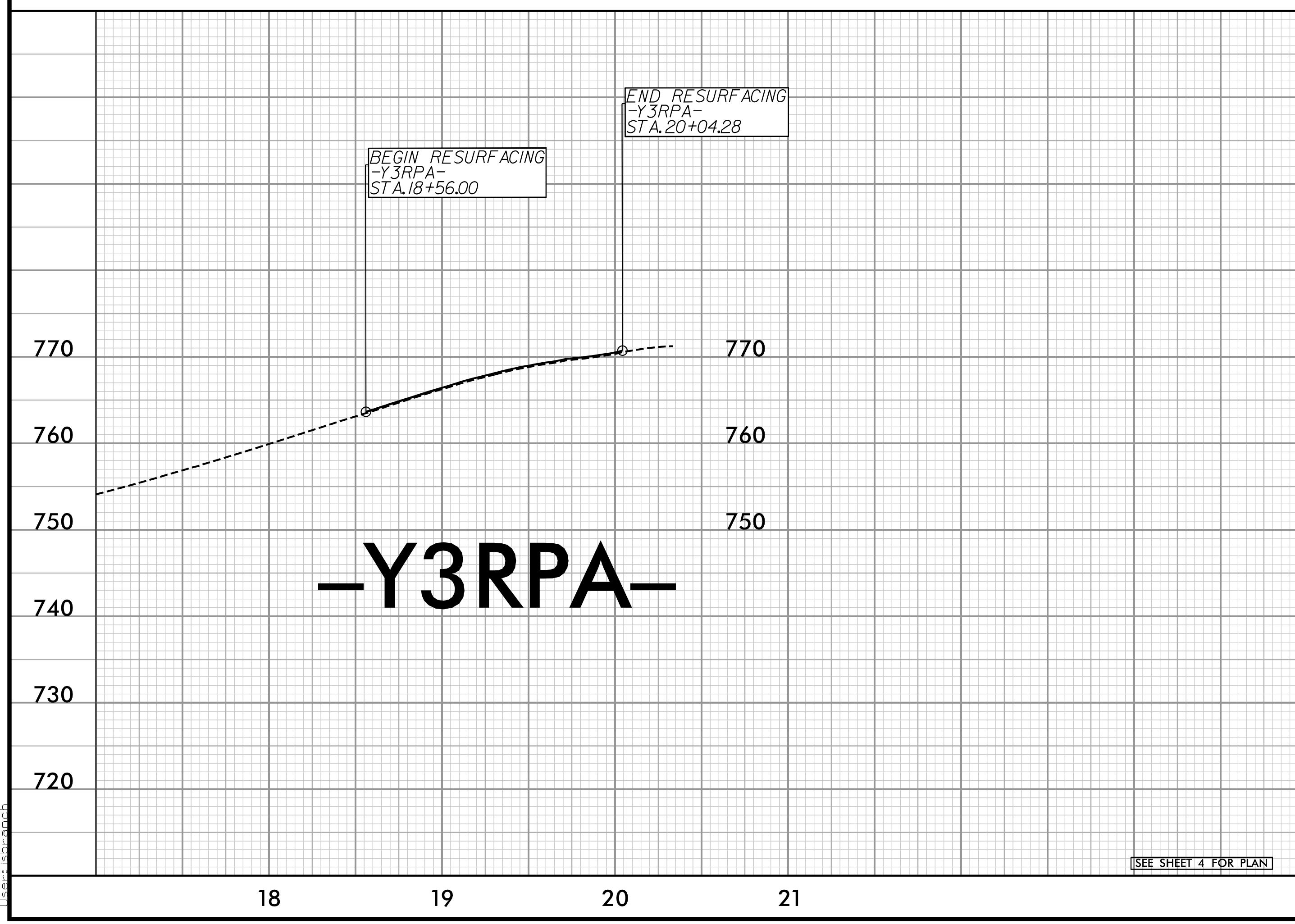
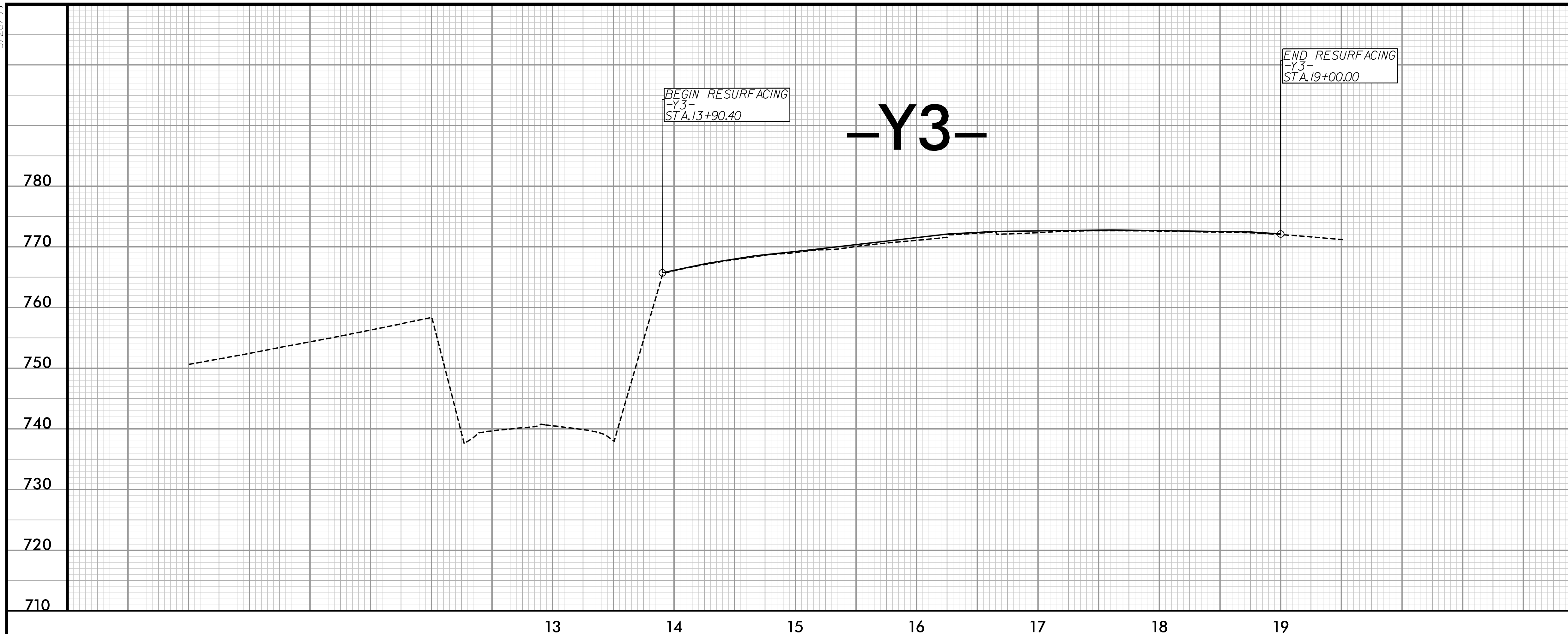

6/10/2020 3:30:50 PM
m:\sect\blumfeld\191633\191633.dgn

STATE	STATE PROJECT REFERENCE NO.	SHEET NO.	TOTAL SHEETS
N.C.	I-5964	RW01	

STATE OF NORTH CAROLINA
 DIVISION OF HIGHWAYS

SURVEY CONTROL, EXISTING CENTERLINES,
 RIGHT OF WAY, EASEMENTS AND PROPERTY TIES

GUILFORD COUNTY

TIP PROJECT: I-5964

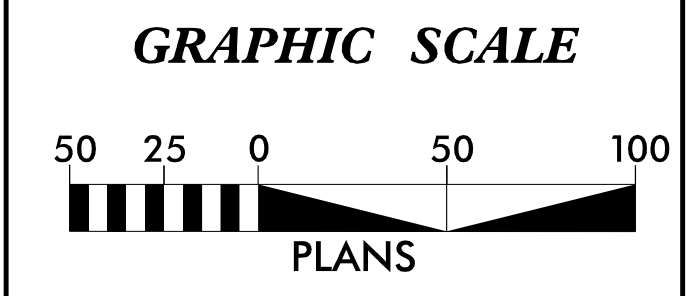
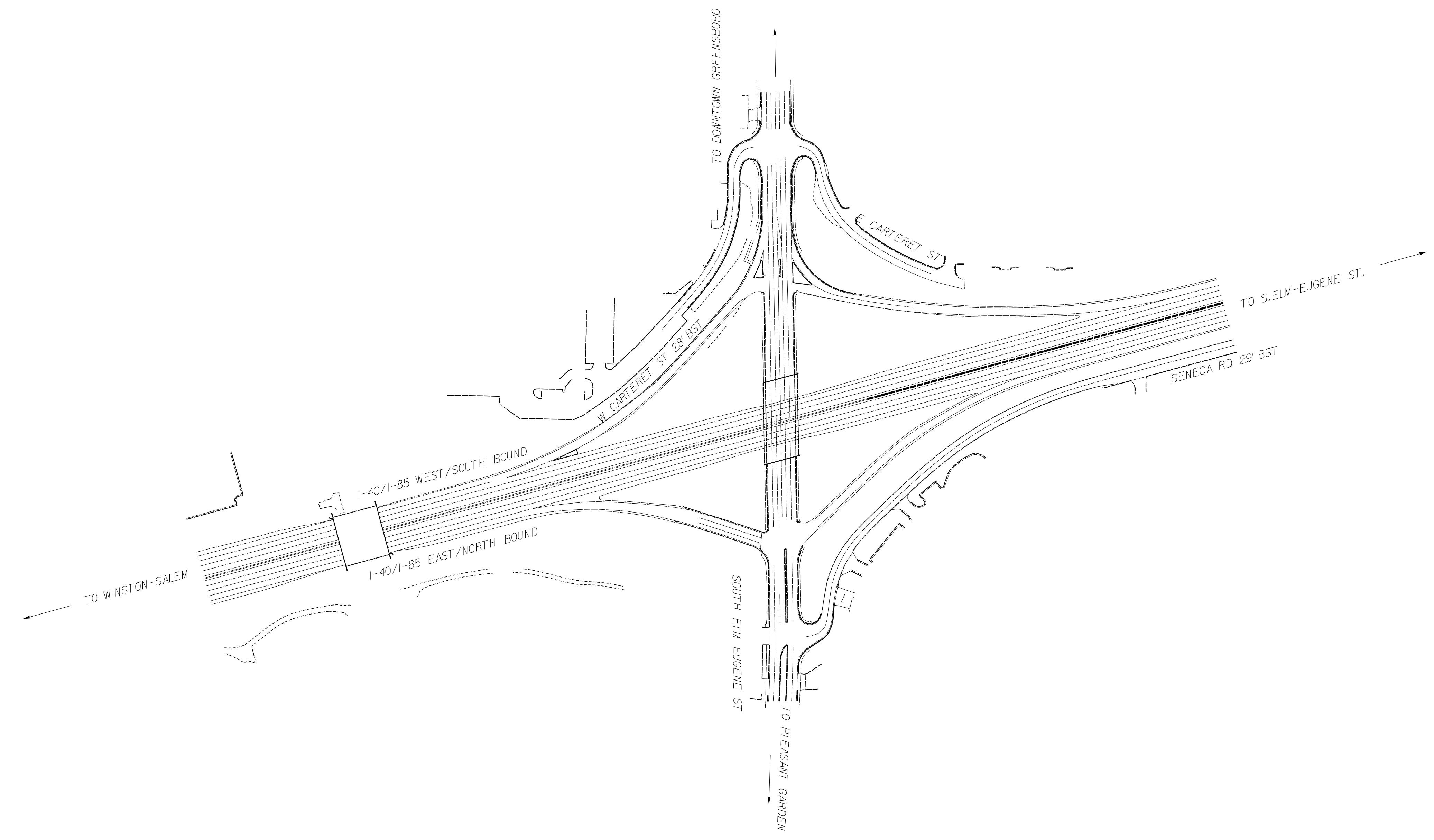

DATUM DESCRIPTION

THE LOCALIZED COORDINATE SYSTEM DEVELOPED FOR THIS PROJECT IS BASED ON THE STATE PLANE COORDINATES ESTABLISHED BY NCGS FOR MONUMENT "B5356-2" WITH NAD 83/NSRS 2011 STATE PLANE GRID COORDINATES OF NORTHING: 832,611.375(ft) EASTING: 1,764,750.401(ft) ELEVATION: 739.16(ft)

THE AVERAGE COMBINED GRID FACTOR USED ON THIS PROJECT (GROUND TO GRID) IS: 0.9999354672

THE N.C. LAMBERT GRID BEARING AND LOCALIZED HORIZONTAL GROUND DISTANCE FROM "B5356-2" TO -L- STATION 10+00.00 IS S 72-35'21.7" W 1,673.73(ft)

ALL LINEAR DIMENSIONS ARE LOCALIZED HORIZONTAL DISTANCES VERTICAL DATUM USED IS NAVD 88

Prepared in the Office of:

2018 STANDARD SPECIFICATIONS

RIGHT OF WAY DATE:	LETTING DATE:
_____	_____

SIGNATURE: _____

Date: _____

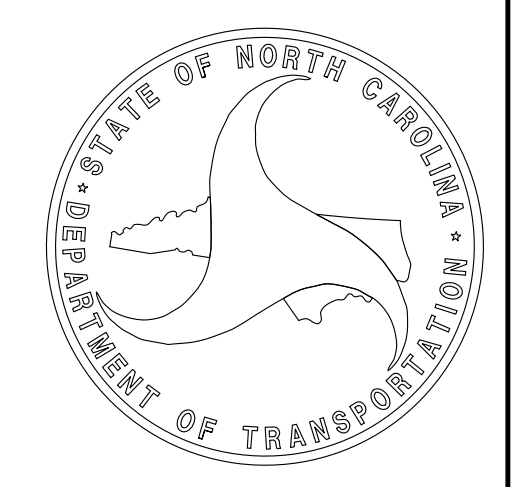

6/10/2020
 V:\Asheville\transportation\31639-03 I-5964 Div 7 I-40 Elm-Eugene Roadway\Proj\I5964_Is_rw01.dgn
 User:tpgarrett

PROJECT REFERENCE NO.	SHEET NO.
I-5964	RW02C-1
Location and Surveys	
VAUGHN & MELTON CONSULTING ENGINEERS	

I-5964 SURVEY CONTROL SHEET

W/ EXISTING CENTERLINE ALIGNMENTS PRIOR TO CONSTRUCTION

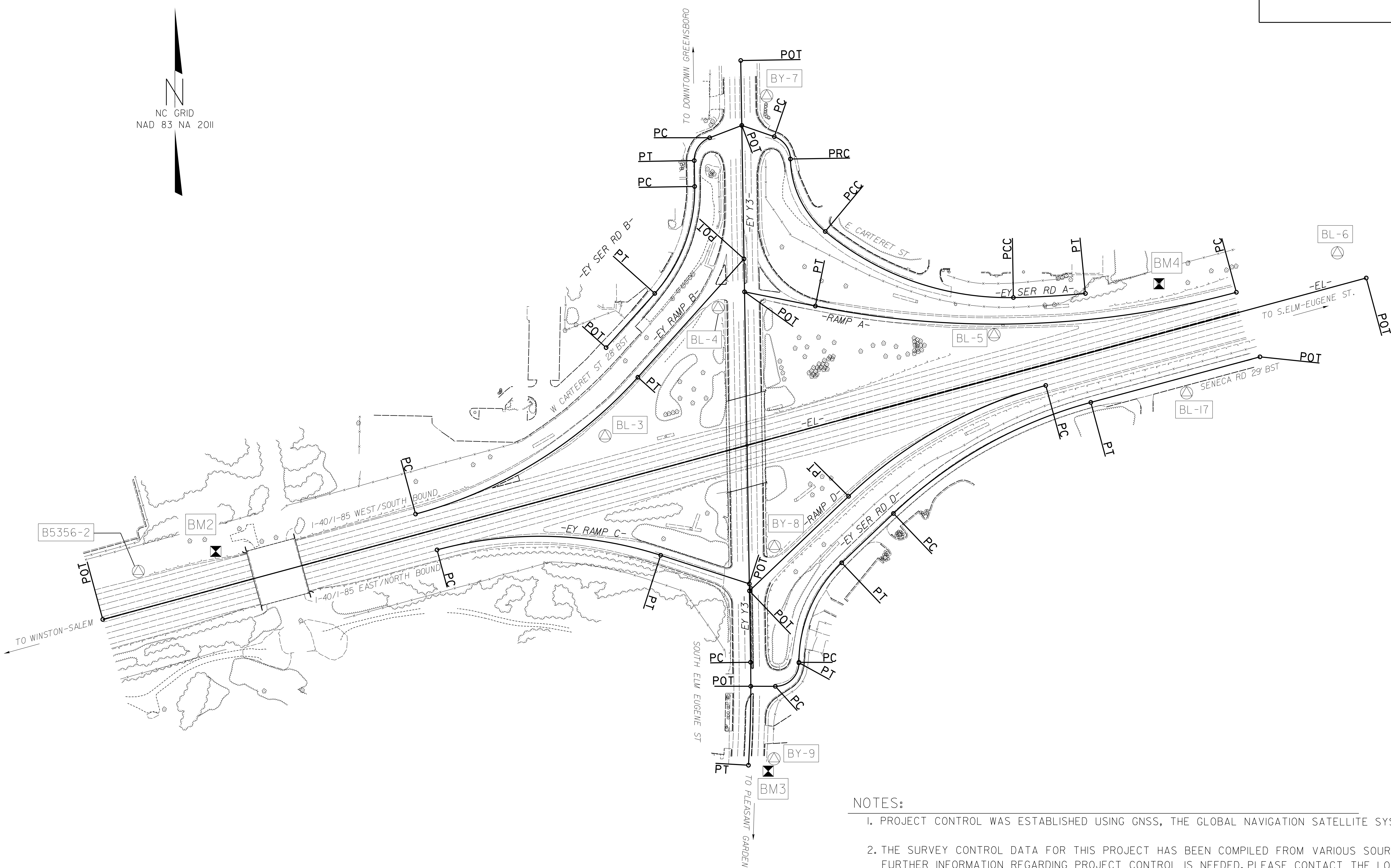

REVISIONS

6/10/2020
 V:\Asheville\transportation\31639-03 I-5964 Div 7 I-40 ELM-Eugene\Roadway\Proj\5964_1s.rw02c-1.dgn
 User:tparrrett

- NOTES:**
- PROJECT CONTROL WAS ESTABLISHED USING GNSS, THE GLOBAL NAVIGATION SATELLITE SYSTEM.
 - THE SURVEY CONTROL DATA FOR THIS PROJECT HAS BEEN COMPILED FROM VARIOUS SOURCES. IF FURTHER INFORMATION REGARDING PROJECT CONTROL IS NEEDED, PLEASE CONTACT THE LOCATION AND SURVEYS UNIT.

PROJECT REFERENCE NO.	SHEET NO.
I-5964	RW02C-2
Location and Surveys	
VAUGHN & MELTON CONSULTING ENGINEERS	

I-5964 SURVEY CONTROL SHEET

W/EXISTING CENTERLINE ALIGNMENTS PRIOR TO CONSTRUCTION

BASELINE DATA

BL - NB	POINT	DESC.	NORTH	EAST	ELEVATION
8		BY-8	832663.1984	1766057.8033	751.86
17		BL-17	833003.8305	1766922.2367	745.61
16		BL-16	833413.9017	1767949.0374	754.12
15		BL-15	833736.6056	1768623.6001	737.38
14		GPS U5754-1	833953.9740	1769113.4530	741.80
EQ13			834238.8795	1769535.0466	751.29

BL - SB	POINT	DESC.	NORTH	EAST	ELEVATION
1		GPS B5356-1	832337.6120	1763625.4680	749.79
2		GPS B5356-2	832611.3750	1764750.4010	739.16
3		BL-3	832902.9433	1765717.7050	743.22
4		BL-4	833174.1617	1765959.3319	769.75
5		BL-5	833120.5681	1766527.1504	746.46
6		BL-6	833283.5393	1767239.7643	747.41
10		BL-10	833514.9724	1767867.6798	752.25
11		BL-11	833752.3291	1768402.4598	742.89
12		BL-12	834008.8206	1768881.0806	741.47
13		GPS U5754-2	834238.8795	1769535.0466	751.29

BY3	POINT	DESC.	NORTH	EAST	ELEVATION
7		BY-7	833602.8662	1766046.2787	769.52
EQ4			833174.1617	1765959.3319	769.75
EQ8			832663.1984	1766057.8033	751.86
9		BY-9	832237.1651	1766056.3816	738.75

BENCHMARK DATA

```

*****
BM2      ELEVATION = 735.08
N 832663      E 1764909
BL STATION (B5356) 18+24.00 4 LEFT
SCRIBE IN CONC FOOT
*****
BM3      ELEVATION = 738.43
N 832210      E 1766055
EY_Y3 STATION 14+65.00
S 78+03'27.9" E      DIST 39.98
SCRIBED "X" IN NE WING WALL OF S. ELMEUGENE ST. BRIDGE OVER SOUTH BUFFALOCREEK
*****
BM4      ELEVATION = 757.53
N 833219      E 1766869
EY_SER-RDA STATION 18+78.00
N 82+27'41.0" E      DIST 154.28
RAILROAD SPIKE SET IN 36" OAK TREE
*****
    
```

NOTES:

1. PROJECT CONTROL WAS ESTABLISHED USING GNSS, THE GLOBAL NAVIGATION SATELLITE SYSTEM.
2. THE SURVEY CONTROL DATA FOR THIS PROJECT HAS BEEN COMPILED FROM VARIOUS SOURCES. IF FURTHER INFORMATION REGARDING PROJECT CONTROL IS NEEDED, PLEASE CONTACT THE LOCATION AND SURVEYS UNIT.

6/10/2020
 V:\Asheville\transportation\31639-03 I-5964 Div 7 I-40 E.Im-Eugene\Roadway\Proj\5964-1s.rw02c-2.dgn
 User:tpgarrett

I-5964 SURVEY CONTROL SHEET

W/ EXISTING CENTERLINE ALIGNMENTS PRIOR TO CONSTRUCTION

PROJECT REFERENCE NO.	SHEET NO.
I-5964	RW02C-3
Location and Surveys	
VAUGHN & MELTON CONSULTING ENGINEERS	

EL

POINT	N	E	BEARING	DIST
POT	832110.566	1763153.355		
LINE			N 74°52'30.0" E	4295.13
POT	833231.275	1767299.698		

EY_RAMP_B

POINT	N	E	BEARING	DIST	DELTA	D	L	T	R
PC	832740.530	1765324.057							
CURVE			N 58°22'30.0" E	542.43	33°00'00.0"(L.T)	06°00'00.0"	550.00	282.86	954.93
PT	833024.957	1765785.935							
LINE			N 41°52'30.0" E	330.48					
POT	833271.033	1766006.533							

EY_RAMP_C

POINT	N	E	BEARING	DIST	DELTA	D	L	T	R
PC	832666.078	1765368.617							
CURVE			S 88°37'30.0" E	464.94	32°59'59.8"(RT)	07°00'00.0"	471.43	242.45	818.51
PT	832654.921	1765833.422							
LINE			S 72°07'30.0" E	193.56					
POT	832595.510	1766017.636							

EY_SER-RDA

POINT	N	E	BEARING	DIST	DELTA	D	L	T	R
POT	833548.376	1766001.975							
LINE			S 70°56'29.9" E	71.41					
PC	833525.058	1766069.470							
CURVE			S 35°56'29.9" E	57.36	70°00'00.0"(RT)	114°35'29.6"	61.09	35.01	50.00
PCC	833478.621	1766103.137							
CURVE			S 25°38'02.5" E	167.10	49°23'05.2"(L.T)	28°38'52.4"	172.39	91.96	200.00
PCC	833327.969	1766175.427							
CURVE			S 70°38'20.1" E	414.46	40°37'30.0"(L.T)	09°35'52.5"	423.27	220.97	596.96
PCC	833190.567	1766566.447							
CURVE			N 86°43'54.9" E	149.96	04°38'00.0"(L.T)	03°05'20.0"	150.00	75.04	1854.90
PT	833199.116	1766716.162							

EY_SER-RDB

POINT	N	E	BEARING	DIST	DELTA	D	L	T	R
POT	833548.376	1766001.975							
LINE			S 69°03'30.1" W	71.41					
PC	833522.853	1765935.282							
CURVE			S 34°03'30.1" W	57.36	70°00'00.0"(L.T)	114°35'29.6"	61.09	35.01	50.00
PT	833475.334	1765903.159							
LINE			S 00°56'29.9" E	53.80					
PC	833421.541	1765904.043							
CURVE			S 20°28'00.1" W	237.26	42°49'00.0"(RT)	17°37'46.1"	242.87	127.42	325.00
PT	833199.260	1765821.083							
LINE			S 41°52'30.1" W	151.42					
POT	833086.512	1765720.009							

EY_SER-RDD

POINT	N	E	BEARING	DIST	DELTA	D	L	T	R
POT	832382.554	1766020.700							
LINE			S 89°56'29.9" E	51.00					
PC	832382.503	1766071.700							
CURVE			N 45°03'30.1" E	69.30	90°00'00.0"(L.T)	116°55'48.6"	76.97	49.00	49.00
PT	832431.453	1766120.750							
LINE			N 00°03'30.1" E	0.82					
PC	832432.273	1766120.750							
CURVE			N 23°13'00.1" E	225.33	46°19'00.0"(RT)	19°59'59.7"	231.58	122.54	286.48
PT	832639.355	1766209.578							
LINE			N 46°22'30.1" E	148.57					
PC	832741.859	1766317.123							
CURVE			N 60°38'30.1" E	470.66	28°32'00.0"(RT)	06°00'00.0"	475.56	242.82	954.93
PT	832972.608	1766727.334							
LINE			N 74°54'30.1" E	364.08					
POT	833067.400	1767078.853							

EY_Y3

POINT	N	E	BEARING	DIST	DELTA	D	L	T	R
POT	833683.358	1765999.756							
LINE			S 00°56'29.9" E	1250.97					
PC	832432.552	1766020.314							
CURVE			S 01°12'00.1" W	214.12	04°17'00.0"(RT)	02°00'00.0"	214.17	107.13	2864.79
PT	832218.482	1766015.830							

RAMP A

POINT	N	E	BEARING	DIST	DELTA	D	L	T	R
PC	833201.586	1767029.846							
CURVE			S 88°07'30.0" W	875.48	26°30'00.0"(RT)	03°00'00.0"	883.33	449.71	1909.86
PT	833172.941	1766154.834							
LINE			N 78°37'30.0" W	150.12					
POT	833202.550	1766007.659							

RAMP D

POINT	N	E	BEARING	DIST	DELTA	D	L	T	R
PC	833007.997	1766633.633							
CURVE			S 60°37'30.0" W	470.12	28°30'00.0"(L.T)	06°00'00.0"	475.00	242.52	954.93
PT	832777.393	1766223.959							
LINE			S 46°22'30.0" W	284.70					
POT	832580.971	1766017.875							

NOTES:

1. PROJECT CONTROL WAS ESTABLISHED USING GNSS, THE GLOBAL NAVIGATION SATELLITE SYSTEM.
2. THE SURVEY CONTROL DATA FOR THIS PROJECT HAS BEEN COMPILED FROM VARIOUS SOURCES. IF FURTHER INFORMATION REGARDING PROJECT CONTROL IS NEEDED, PLEASE CONTACT THE LOCATION AND SURVEYS UNIT.

STATE OF NORTH CAROLINA
DIVISION OF HIGHWAYS

TRANSPORTATION MANAGEMENT PLAN

**GUILFORD COUNTY
DIVISION 7**

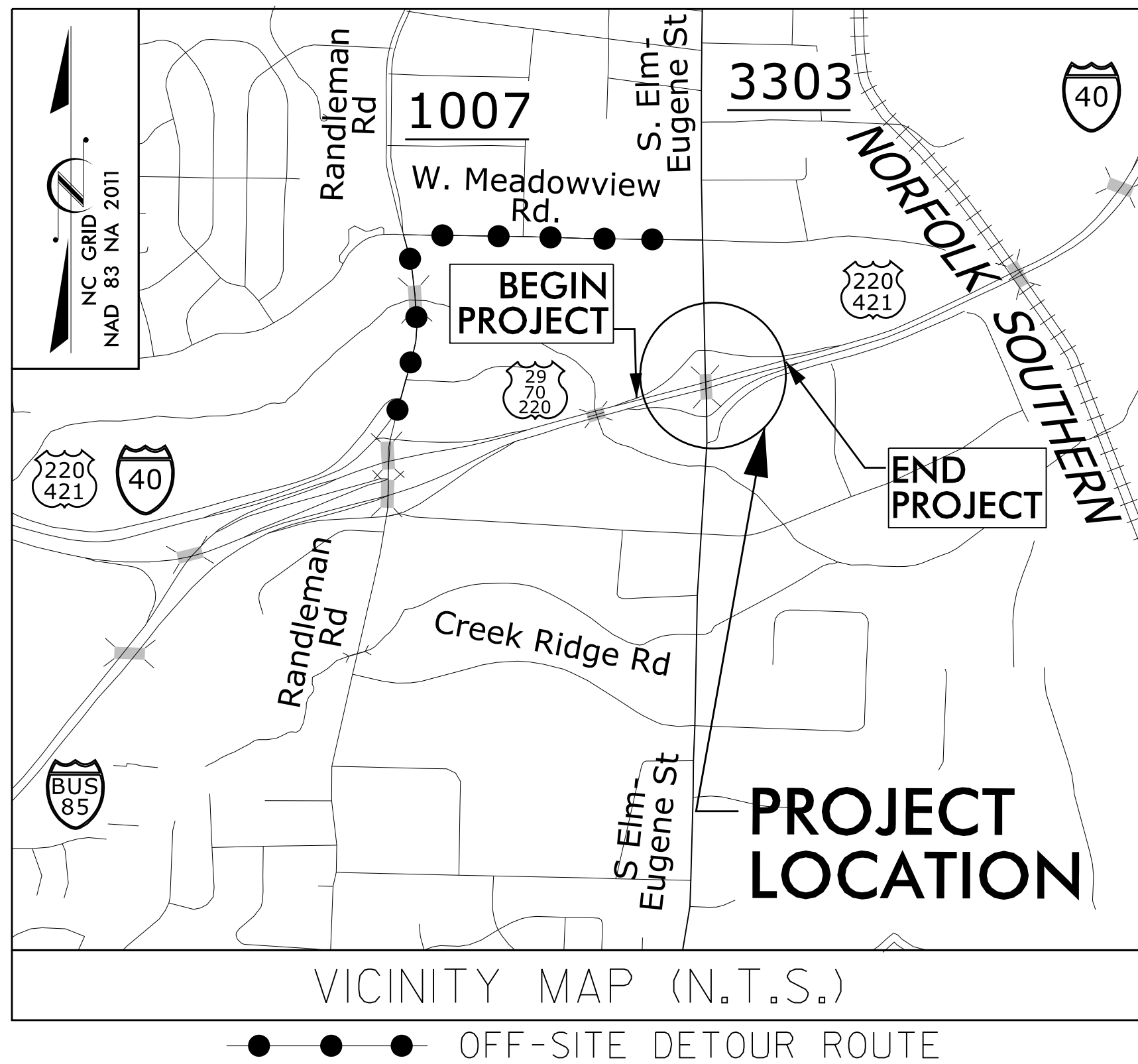
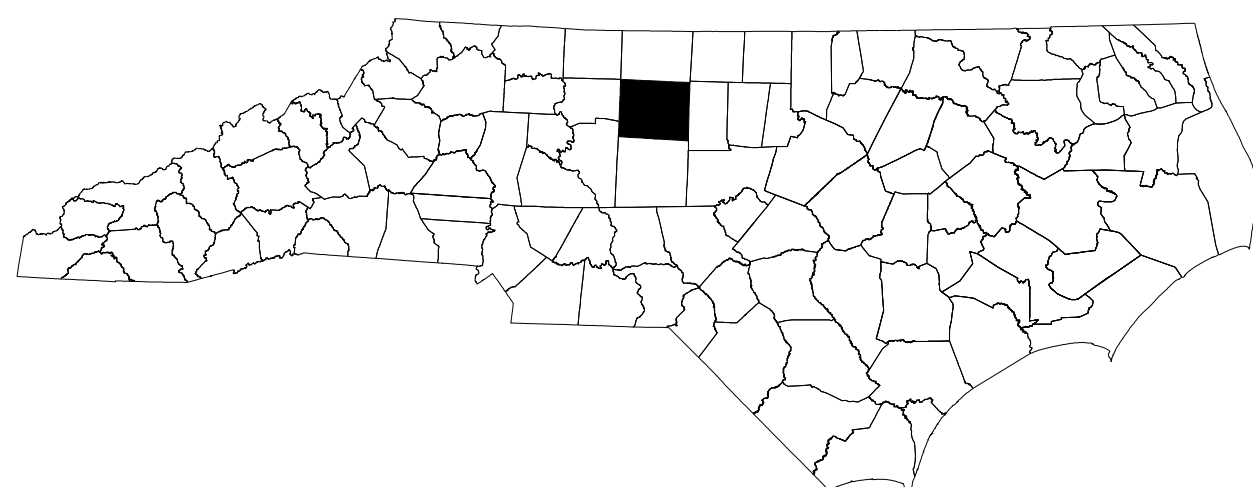

LOCATION: I-40/I-85 BUS./SOUTH ELM-EUGENE STREET INTERCHANGE IMPROVEMENTS

INDEX OF SHEETS

SHEET NO.	TITLE
TMP-1	TITLE SHEET, LEGEND, AND INDEX OF SHEETS
TMP-1A	LIST OF APPLICABLE ROADWAY STANDARD DRAWINGS, GENERAL NOTES AND TRANSPORTATION OPERATIONS
TMP-1B	LIST OF APPLICABLE ROADWAY STANDARD DRAWINGS, GENERAL NOTES AND TRANSPORTATION OPERATIONS
TMP-2	SPECIAL SIGN DESIGN
TMP-3	TEMPORARY TRAFFIC CONTROL DEVICES, SIGNING AND PHASING NOTES
TMP-4	OFF-SITE DETOUR SIGNING AND ROAD CLOSURE
TMP-5	TEMPORARY PEDESTRIAN DETOUR DETAIL

LEGEND

GENERAL

NORTH ARROW

TRAFFIC CONTROL DEVICES

BARRICADE (TYPE III)

DRUMS

CHANGEABLE MESSAGE SIGN

LAW ENFORCEMENT

TEMPORARY SIGNING

STATIONARY SIGN

PORTABLE SIGN

**DOCUMENT NOT CONSIDERED FINAL
UNLESS ALL SIGNATURES COMPLETED**

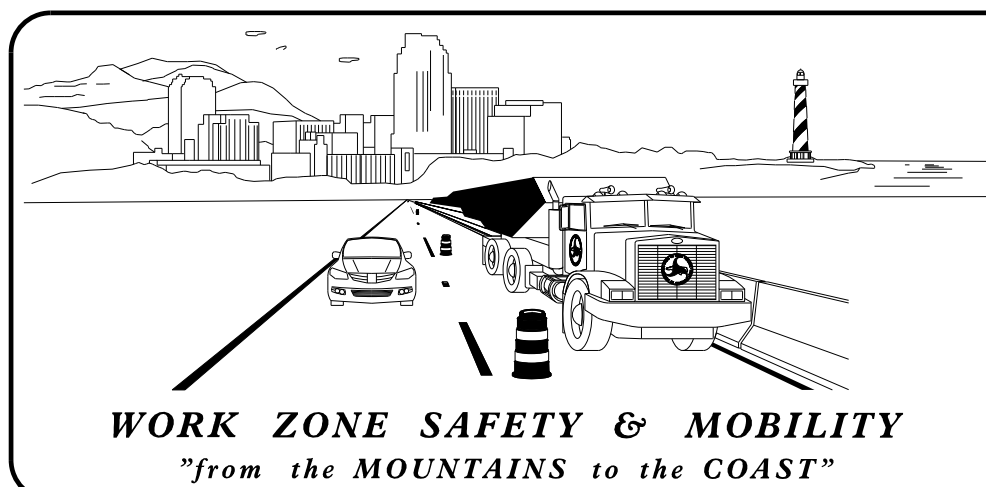

PLANS PREPARED BY:

LLOYD DEWAYNE BROWN, PE, PLS
PROJECT ENGINEER

CHRIS MARTELL
PROJECT DESIGN ENGINEER

NCDOT CONTACTS:

JOSEPH E. HUMMER, PE
PROJECT ENGINEER

PROJECT DESIGN ENGINEER

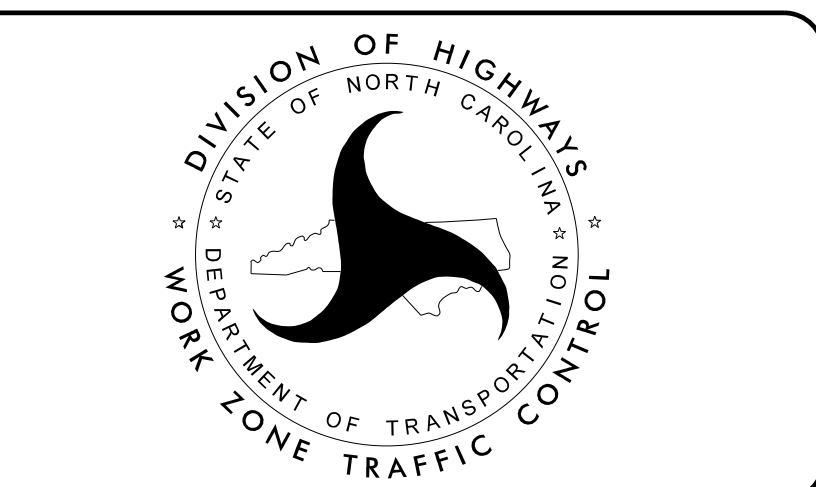

V&M
Vaughn & Melton
Consulting Engineers

Asheville, North Carolina
828-253-1795

Raleigh, NC 919-977-9455
Charlotte, NC 704-357-0488

Boone, NC 828-355-9333
Tri-Cities, TN 423-467-8401
Knoxville, TN 865-946-5850
Spartanburg, SC 864-514-4175
Charleston, SC 843-974-5650
Mississippi, KY 606-248-6600
Atlanta, GA 770-627-3590

Copyright © 2006 Vaughn & Melton, Inc. All Rights Reserved

APPROVED:

DATE: 7/12/2021

SEAL

7/9/2021 3:07:55 PM V:\Asheville\Transportation\31639-03 I-5964 Div 7 I-40 Elm-Eugene\TrafficControl\CPN\5964_TC_TMP-1.dgn User: cjmartell

TIP PROJECT: I-5964

ROADWAY STANDARD DRAWINGS

THE FOLLOWING ROADWAY STANDARDS AS SHOWN IN "ROADWAY STANDARD DRAWINGS"- N.C. DEPARTMENT OF TRANSPORTATION - RALEIGH, N.C., DATED JANUARY 2018 ARE APPLICABLE TO THIS PROJECT AND BY REFERENCE HEREBY ARE CONSIDERED A PART OF THESE PLANS:

STD. NO.	TITLE
1101.01	WORK ZONE ADVANCE WARNING SIGNS
1101.02	TEMPORARY LANE CLOSURES
1101.03	TEMPORARY ROAD CLOSURES
1101.11	TRAFFIC CONTROL DESIGN TABLES
1110.01	STATIONARY WORK ZONE SIGNS
1110.02	PORTABLE WORK ZONE SIGNS
1115.01	FLASHING ARROW BOARDS
1130.01	DRUMS
1145.01	BARRICADES
1150.01	FLAGGING DEVICES
1165.01	TRUCK MOUNTED ATTENUATOR
1180.01	SKINNY DRUMS
1205.01	PAVEMENT MARKINGS - LINE TYPES & OFFSETS
1205.02	PAVEMENT MARKINGS - TWO-LANE AND MULTI-LANE ROADWAYS
1205.03	PAVEMENT MARKINGS - EXITS AND ENTRANCE RAMPS
1205.04	PAVEMENT MARKINGS - INTERSECTIONS
1205.05	PAVEMENT MARKINGS - TURN LANES

TRANSPORTATION OPERATIONS

CONSTRUCTION

RESURFACE EXISTING PAVEMENT ALONG THE EXISTING ROADWAY ALIGNMENT/EXISTING RAMPS AS SHOWN IN THE ROADWAY PLANS.

TMP DESIGN PARAMETERS

TRAFFIC WILL BE DETOURED OFF SITE DURING CONSTRUCTION FOR I-40 ON & OFF RAMPS @ EXIT 221 AT NIGHT DURING THE WEEK (SUNDAY THROUGH THURSDAY) AND NARROWED DURING THE DAY. ALLOW RAMPS TO BE OPEN TO TRAFFIC DURING THE WEEKEND PERIODS. USE DRUMS TO SAFELY TRANSITION FROM AN OPEN RAMP SCENARIO TO A CLOSED RAMP SCENARIO.

THE OFF SITE DETOUR WILL INCLUDE W. MEADOWVIEW ROAD AND RANDLEMAN ROAD (SR-1007), SEE TMP-4.

GENERAL NOTES

CHANGES MAY BE REQUIRED WHEN PHYSICAL DIMENSIONS IN THE DETAIL DRAWINGS, STANDARD DETAILS AND ROADWAY DETAILS ARE NOT ATTAINABLE TO MEET FIELD CONDITIONS, OR RESULT IN DUPLICATE, OR UNDESIRED OVERLAPPING OF DEVICES. MODIFICATION MAY INCLUDE: MOVING, SUPPLEMENTING, COVERING OR REMOVAL OF DEVICES, AS DIRECTED BY THE ENGINEER.

THE FOLLOWING GENERAL NOTES APPLY AT ALL TIMES FOR THE DURATION OF THE CONSTRUCTION PROJECT, EXCEPT WHEN OTHERWISE NOTED IN THE PLAN, OR DIRECTED BY THE ENGINEER.

TRAFFIC PATTERN ALTERATIONS

- A) NOTIFY THE ENGINEER THIRTY (30) CALENDAR DAYS PRIOR TO ANY TRAFFIC PATTERN ALTERATION.
- B) MAINTAIN DRIVEWAY ACCESS AT ALL TIMES DURING CONSTRUCTION.

SIGNING

- C) PROVIDE TEMPORARY SIGNING.
- D) PROVIDE SIGNING AND DEVICES REQUIRED TO CLOSE THE ROAD ACCORDING TO THE ROADWAY STANDARD DRAWINGS AND TRAFFIC CONTROL PLANS.
- E) PROVIDE SIGNING REQUIRED FOR THE OFF-SITE DETOUR ROUTE AS SHOWN IN THE TRAFFIC CONTROL PLANS.
- F) COVER OR REMOVE ALL SIGNS AND DEVICES REQUIRED TO CLOSE THE ROAD WHEN ROAD CLOSURE IS NOT IN OPERATION.
- G) COVER OR REMOVE ALL SIGNS REQUIRED FOR THE OFF-SITE DETOUR WHEN THE DETOUR IS NOT IN OPERATION.
- H) ENSURE ALL NECESSARY SIGNING IS IN PLACE PRIOR TO ALTERING ANY TRAFFIC PATTERN.

TRAFFIC CONTROL DEVICES

- I) PLACE TYPE III BARRICADES WITH "ROAD CLOSED" SIGN R-11-2 ATTACHED OF SUFFICIENT LENGTH TO CLOSE ENTIRE ROADWAY.
- J) WHEN LANE CLOSURES ARE NOT IN EFFECT SPACE CHANNELIZING DEVICES IN WORK AREAS NO GREATER IN FEET THAN TWICE THE POSTED SPEED LIMIT (MPH) EXCEPT 10 FT ON-CENTER IN RADII, AND 3 FT OFF THE EDGE OF AN OPEN TRAVELWAY. REFER TO STANDARD SPECIFICATIONS FOR ROADS AND STRUCTURES SECTIONS 1130 (DRUMS), 1135 (CONES) AND 1180 (SKINNY DRUMS) FOR ADDITIONAL REQUIREMENTS.

PAVEMENT MARKINGS AND MARKERS

- K) INSTALL TEMPORARY PAVEMENT MARKINGS ON INTERIM LAYERS OF PAVEMENT AS FOLLOWS:

ROAD NAME	MARKING	MARKER
I-40 WB Ramps	PAINT	N/A
S. Elm-Eugene St.		

- L) INSTALL PAVEMENT MARKINGS (THERMO) ON THE FINAL SURFACE OF THE ENTIRE PROJECT.
- M) TIE PROPOSED PAVEMENT MARKING LINES TO EXISTING PAVEMENT MARKING LINES.

LANE AND SHOULDER CLOSURE REQUIREMENTS

- N) REMOVE LANE CLOSURE DEVICES FROM THE LANE WHEN WORK IS NOT BEING PERFORMED BEHIND THE LANE CLOSURE OR WHEN A LANE CLOSURE IS NO LONGER NEEDED OR AS DIRECTED BY THE ENGINEER.
- O) WHEN PERSONNEL AND/OR EQUIPMENT ARE WORKING WITHIN 15 FT OF AN OPEN TRAVEL LANE, CLOSE THE NEAREST OPEN SHOULDER USING ROADWAY STANDARD DRAWING NO. 1101.04 UNLESS THE WORK AREA IS PROTECTED BY BARRIER OR GUARDRAIL OR A LANE CLOSURE IS INSTALLED.
- P) WHEN PERSONNEL AND/OR EQUIPMENT ARE WORKING ON THE SHOULDER ADJACENT TO AN UNDIVIDED FACILITY AND WITHIN 5 FT OF AN OPEN TRAVEL LANE, CLOSE THE NEAREST OPEN TRAVEL LANE USING ROADWAY STANDARD DRAWING NO. 1101.02 UNLESS THE WORK AREA IS PROTECTED BY BARRIER OR GUARDRAIL.
- Q) WHEN PERSONNEL AND/OR EQUIPMENT ARE WORKING WITHIN A LANE OF TRAVEL OF AN UNDIVIDED OR DIVIDED FACILITY, CLOSE THE LANE ACCORDING TO THE TRAFFIC CONTROL PLANS, ROADWAY STANDARD DRAWINGS, OR AS DIRECTED BY THE ENGINEER. CONDUCT THE WORK SO THAT ALL PERSONNEL AND/OR EQUIPMENT REMAIN WITHIN THE CLOSED TRAVEL LANE.
- R) DO NOT WORK SIMULTANEOUSLY WITHIN 15 FT ON BOTH SIDES OF AN OPEN TRAVELWAY, RAMP, OR LOOP WITHIN THE SAME LOCATION UNLESS PROTECTED WITH GUARDRAIL OR BARRIER

PAVEMENT EDGE DROP OFF REQUIREMENTS

- S) BACKFILL AT A 6:1 SLOPE UP TO THE EDGE AND ELEVATION OF EXISTING PAVEMENT IN AREAS ADJACENT TO AN OPENED TRAVEL LANE THAT HAS AN EDGE OF PAVEMENT DROP-OFF AS FOLLOWS:

BACKFILL DROP-OFFS THAT EXCEED 2 INCHES ON ROADWAYS WITH POSTED SPEED LIMITS OF 45 MPH OR GREATER.

BACKFILL DROP-OFFS THAT EXCEED 3 INCHES ON ROADWAYS WITH POSTED SPEED LIMITS LESS THAN 45 MPH.

BACKFILL WITH SUITABLE COMPACTED MATERIAL, AS APPROVED BY THE ENGINEER, AT NO EXPENSE TO THE DEPARTMENT.

- T) DO NOT EXCEED A DIFFERENCE OF 2 INCHES IN ELEVATION BETWEEN OPEN LANES OF TRAFFIC FOR NOMINAL LIFTS OF 1.5 INCHES. INSTALL ADVANCE WARNING "UNEVEN LANES" SIGNS (W8-11) IN ADVANCE AND A MINIMUM OF EVERY HALF MILE THROUGHOUT THE UNEVEN AREA.

**DOCUMENT NOT CONSIDERED FINAL
UNLESS ALL SIGNATURES COMPLETED**

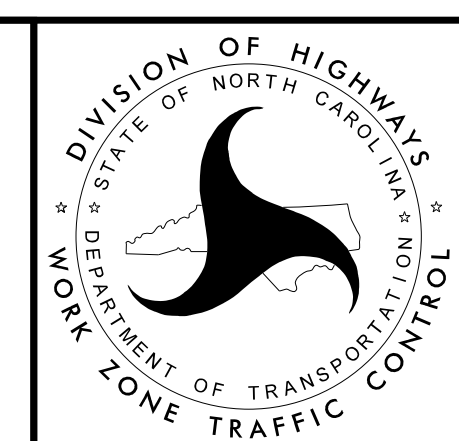
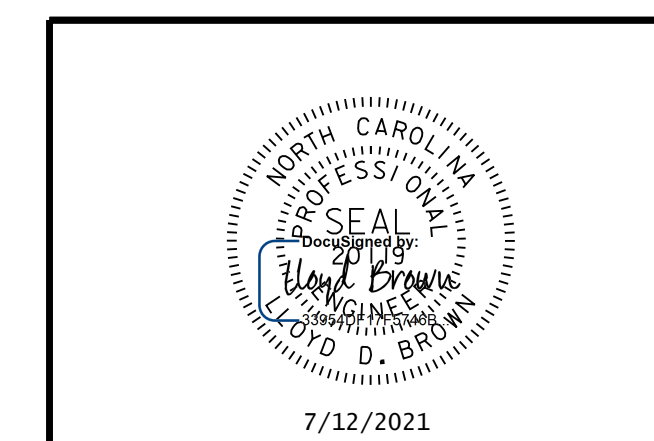

ROADWAY STANDARD DRAWINGS,
GENERAL NOTES &
TRANSPORTATION OPERATIONS

GENERAL NOTES CONT.

MISCELLANEOUS

- U) ALL CURB RAMP LOCATIONS SHALL BE DERIVED FROM STATIONING SHOWN ON PAVEMENT MARKING PLANS OR AS DIRECTED BY THE ENGINEER IN COORDINATION WITH THE SIGNING AND DELINEATION UNIT.
- V) CONTRACTOR SHALL MAINTAIN SIDEWALK ACCESS AT ALL TIMES AS STATED IN THE PHASING. CONTRACTOR SHALL BE RESPONSIBLE TO PROVIDE TEMPORARY SIDEWALKS (CONCRETE, ASPHALT, OR OTHER SUITABLE MATERIAL AS APPROVED BY THE ENGINEER) AT ALL LOCATIONS WHERE THE OPEN PEDESTRIAN TRAVELWAY HAS BEEN REMOVED FOR CONSTRUCTION OPERATIONS (UTILITIES, DRAINAGE, ETC.).
- W) CONTRACTOR SHALL REOPEN LANES WHEN WORK WORK IS NOT BEING COMPLETED.
- X) NOTIFY GUILFORD COUNTY EMERGENCY SERVICES AND PUBLIC SCHOOLS AT LEAST ONE MONTH PRIOR TO ROAD CLOSURE.
- Y) LAW ENFORCEMENT SHALL BE USED TO MAINTAIN TRAFFIC THROUGH THE WORK AREA AND/OR INTERSECTIONS AS DIRECTED BY THE ENGINEER.

TIME RESTRICTIONS

Z) DO NOT CLOSE OR NARROW TRAVEL LANES AS FOLLOWS:

<u>ROAD NAME</u>	<u>DAY AND TIME RESTRICTIONS</u>
S. Elm-Eugene St.	MONDAY THRU SUNDAY, 6:00 AM TO 8:00 PM
I-40 WB Ramps	MONDAY THRU SUNDAY, 6:00 AM TO 10:00 PM

AA) DO NOT CLOSE OR NARROW TRAVEL LANES DURING HOLIDAYS AND SPECIAL EVENTS AS FOLLOWS:

<u>ROAD NAME</u>
S. Elm-Eugene St.

HOLIDAY

- 1. FOR ANY UNEXPECTED OCCURRENCE THAT CREATES UNUSUALLY HIGH TRAFFIC VOLUMES, AS DIRECTED BY THE ENGINEER.
- 2. FOR NEW YEAR'S, BETWEEN THE HOURS OF 7:00 A.M. DECEMBER 31st TO 9:00 P.M. JANUARY 2ND. IF NEW YEAR'S DAY IS ON A FRIDAY, SATURDAY, SUNDAY, OR MONDAY THEN UNTIL 9:00 P.M. THE FOLLOWING TUESDAY.

HOLIDAY CONT.

- 3. FOR EASTER, BETWEEN THE HOURS OF 7:00 A.M. THURSDAY AND 9:00 P.M. MONDAY.
- 4. FOR MEMORIAL DAY, BETWEEN THE HOURS OF 7:00 A.M. FRIDAY TO 9:00 P.M. TUESDAY.
- 5. FOR INDEPENDENCE DAY, BETWEEN THE HOURS OF 7:00 A.M. THE DAY BEFORE INDEPENDENCE DAY AND 9:00 P.M. THE DAY AFTER INDEPENDENCE DAY.

IF INDEPENDENCE DAY IS ON A FRIDAY, SATURDAY, SUNDAY OR MONDAY THEN BETWEEN THE HOURS OF 7:00 A.M. THE THURSDAY BEFORE INDEPENDENCE DAY AND 9:00 P.M. THE TUESDAY AFTER INDEPENDENCE DAY.
- 6. FOR LABOR DAY, BETWEEN THE HOURS OF 7:00 A.M. FRIDAY AND 9:00 P.M. TUESDAY.
- 7. FOR THANKSGIVING DAY, BETWEEN THE HOURS OF 7:00 A.M. TUESDAY TO 9:00 P.M. MONDAY.
- 8. FOR CHRISTMAS, BETWEEN THE HOURS OF 7:00 A.M. THE FRIDAY BEFORE THE WEEK OF CHRISTMAS DAY AND 9:00 P.M. THE FOLLOWING TUESDAY AFTER THE WEEK OF CHRISTMAS.

BB) DO NOT CLOSE ROADS AS FOLLOWS AND DURING HOLIDAYS AND SPECIAL EVENTS PER NOTE AA):

<u>ROAD NAME</u>	<u>DAY AND TIME RESTRICTIONS</u>
I-40 WB Ramps	MONDAY THRU SUNDAY, 6:00 AM TO 10:00 PM

CC) LANE CLOSURES ARE NOT ALLOWED ON I-40.

10/1/2021 9:24:49 AM V:\Asheville\Transportation\31639-03 I-5964 Div 7 I-40 Elm-Eugene\TrafficControl\TCP\5964_TC_TMP-1A.dgn User:tcimarbell

**DOCUMENT NOT CONSIDERED FINAL
UNLESS ALL SIGNATURES COMPLETED**

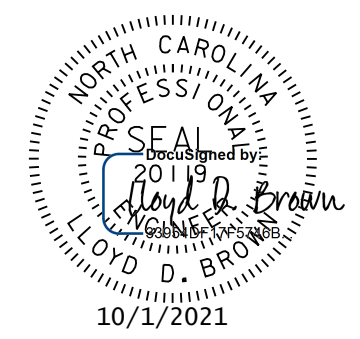
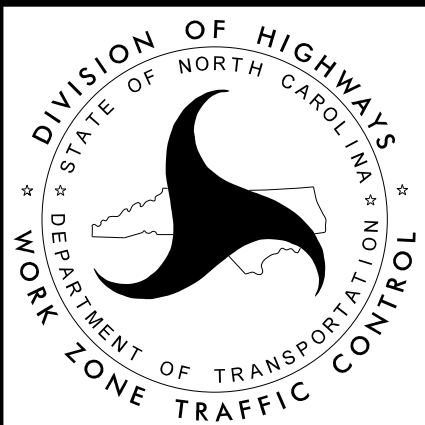
		<p>ROADWAY STANDARD DRAWINGS, GENERAL NOTES & TRANSPORTATION OPERATIONS</p>
---	---	--

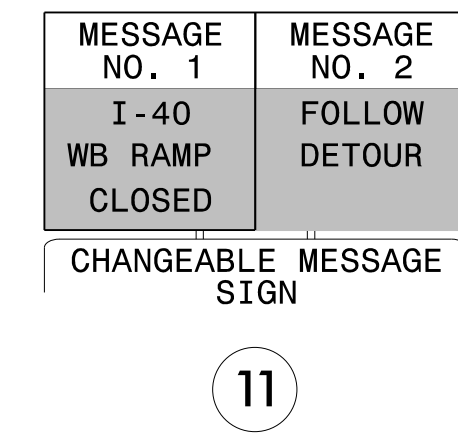
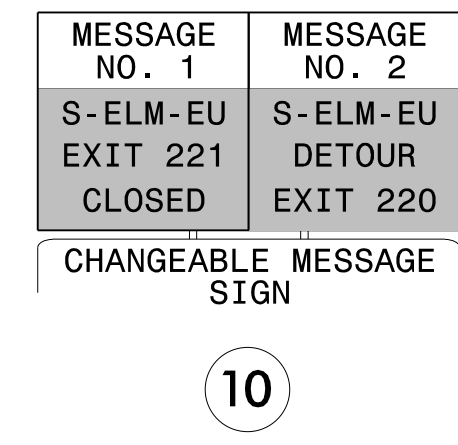
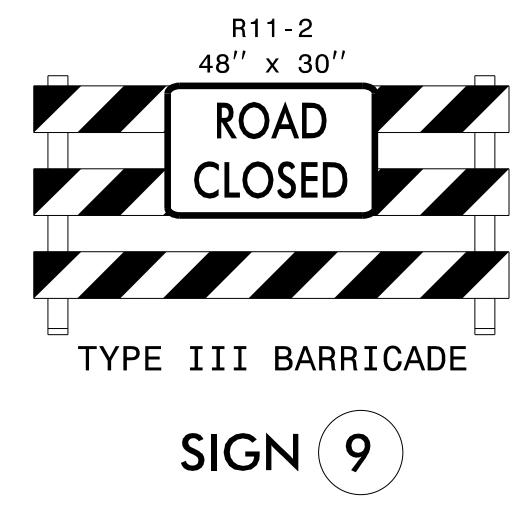
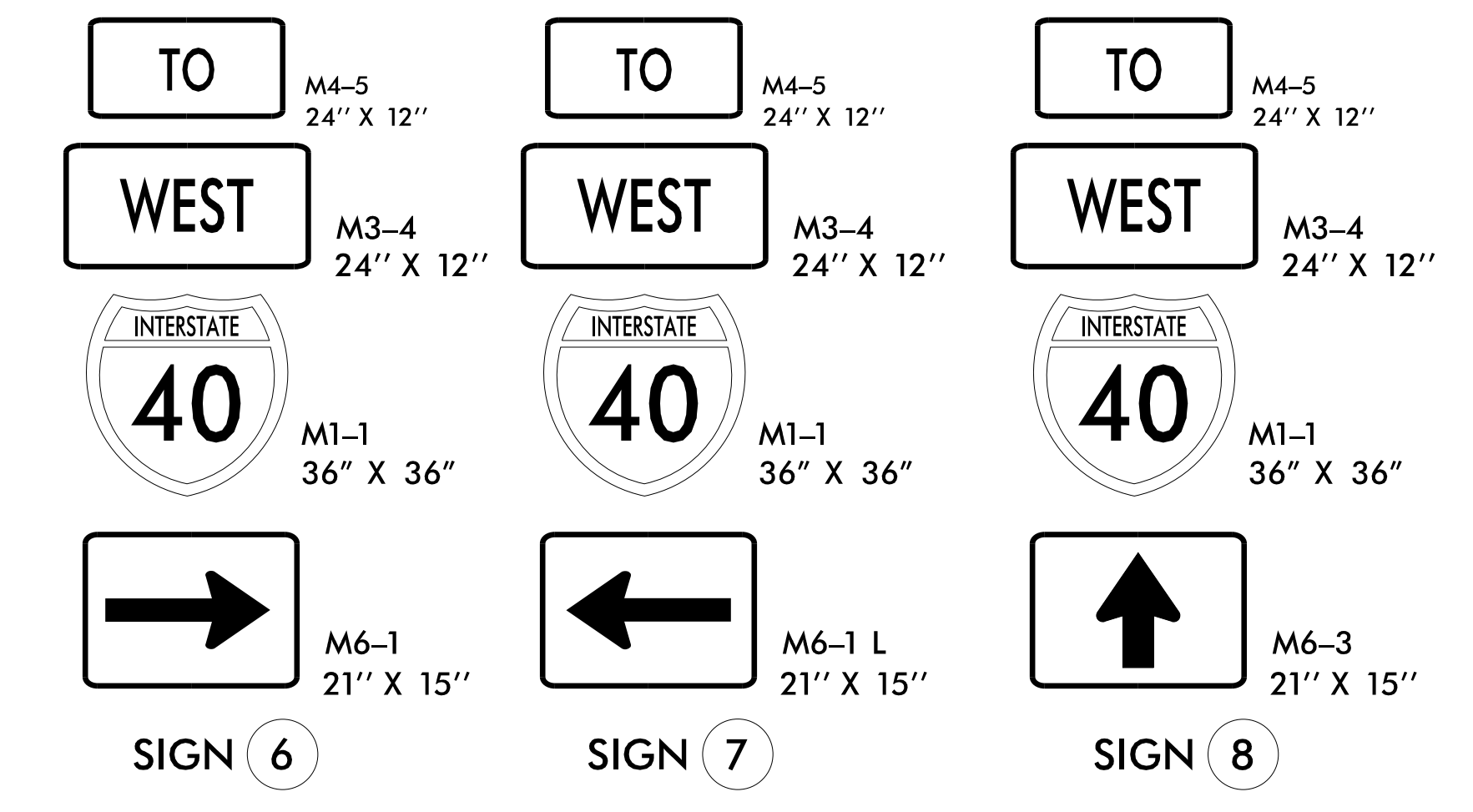
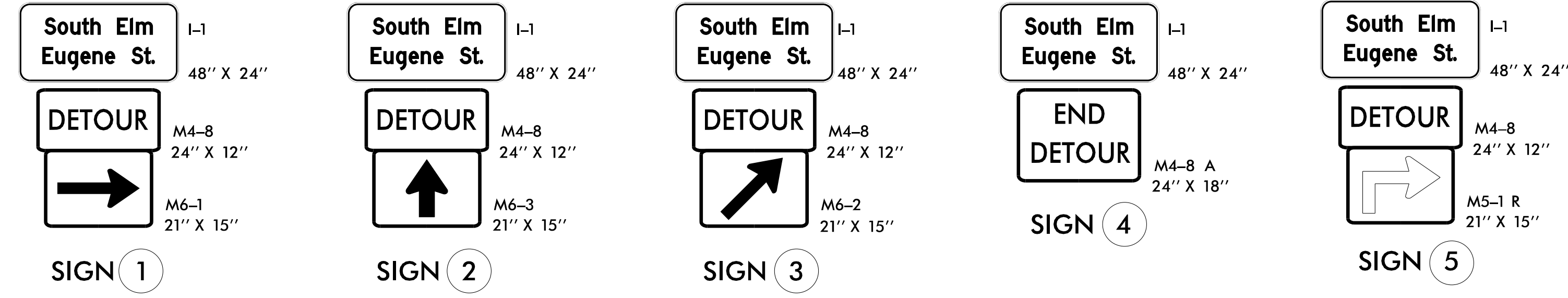
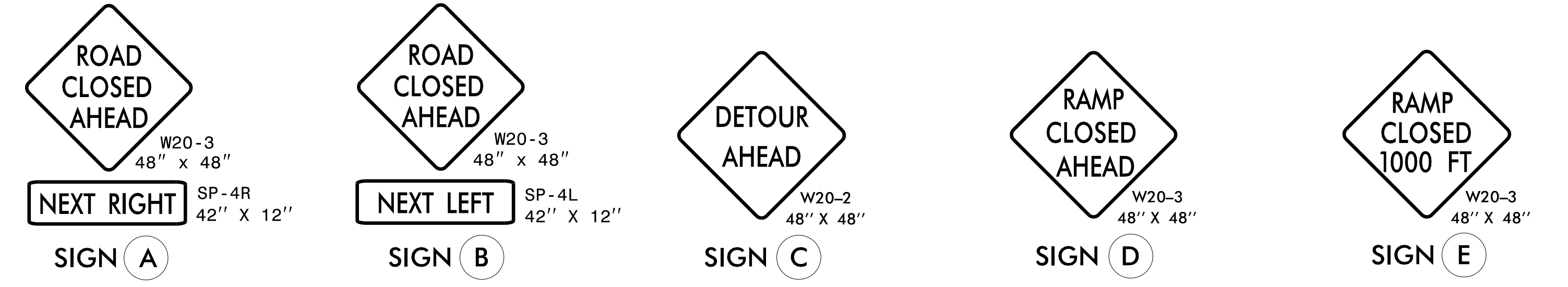

NOTES:

- ALL DETOUR SIGN LOCATIONS ARE APPROXIMATE.
- ALL DETOUR SIGNS ARE BLACK ON ORANGE UNLESS OTHERWISE NOTED.
- TRAFFIC CONTROL DEVICES (A) THROUGH (E) SHALL BE INSTALLED ACCORDING TO ROADWAY STANDARD DRAWING 1101.03, SHEET 1 OF 9.
- TRAFFIC CONTROL DEVICES (1) AND (11) SHALL BE INSTALLED AS PER ENGINEER'S INSTRUCTIONS, AND AS SHOWN HEREON.
- * SEE ROADWAY STANDARD DRAWING NO. 1101.03, SHEET 1 OF 9 AND 2 OF 9, FOR ADDITIONAL WORK ZONE SIGNS, BARRICADES AND NOTES.

PHASING

- STEP 1:** - ERECT WORK ZONE ADVANCE WARNING SIGNS ON -Y3-(ELM EUGENE), -Y3RPB-, -Y3RPA-, AND I-40.
- INSTALL OFF-SITE DETOUR ROUTE SIGN ASSEMBLIES FOR THE CLOSING OF I-40 WESTBOUND ON & OFF RAMP @ EXIT 221 (SEE TMP-4).
 - CLOSE I-40 WESTBOUND ON & OFF RAMP @ EXIT 221 TO TRAFFIC ON A NIGHTLY BASIS (SEE TMP-4) OR NARROW A RAMP LANE ON A DAILY BASIS (SEE RDVY STD. DRAWING 1101.02, SEE SHEET 1 OF 14).
 - CLOSE SIDEWALKS ON RIGHT SIDE LOOKING UPSTATION & DETOUR PEDESTRIANS TO THE OPPOSITE SIDE OF THE STREET FROM THE WORK SITE (SEE TMP-5).
 - ONLY PERFORM WORK ON ONE SIDE OF THE STREET AT A TIME FOR SIDEWALK CONSTRUCTION. LEAVE ONE SIDE OPEN FOR PEDESTRIAN USE. USE ONLY ADA COMPLIANT BARRICADES.
 - REMOVE EXISTING SIDEWALK, CURB RAMPS, CONCRETE ISLANDS, AND CURB & GUTTER. PLACE PROPOSED SIDEWALK, CURB RAMPS. RESURFACE/WIDEN THE EXISTING PAVEMENT ALONG THE EXISTING ROADWAY ALIGNMENT/EXISTING RAMPS AS SHOWN IN THE ROADWAY PLANS. NOTE: WORK SHOULD BE COMPLETED IN A CONTINUOUS MANNER. SEE ICT FOR CONSTRUCTION TIME AND LIQUIDATED DAMAGES.
- STEP 2:** - CLOSE SIDEWALKS ON LEFT SIDE LOOKING UPSTATION & DETOUR PEDESTRIANS TO THE OPPOSITE SIDE OF THE STREET FROM THE WORK SITE (SEE TMP-5).
- NOTE: ONLY PERFORM WORK ON ONE SIDE OF THE STREET AT A TIME FOR SIDEWALK CONSTRUCTION. LEAVE ONE SIDE OPEN FOR PEDESTRIAN USE. USE ONLY ADA COMPLIANT BARRICADES.

INTERMEDIATE CONTRACT TIME (ICT)

COMPLETE THE WORK REQUIRED IN STEPS 1 THRU 3 WITHIN A PERIOD OF 92 CONSECUTIVE CALENDAR DAYS.

ICT

STEP 2 CONT:

- REMOVE EXISTING SIDEWALK, CURB RAMPS, CONCRETE ISLANDS, AND CURB & GUTTER. PLACE PROPOSED SIDEWALK, CURB RAMPS, AND NEW CHAIN LINK FENCE. RESURFACE/WIDEN THE EXISTING PAVEMENT ALONG THE EXISTING EXISTING RAMPS AS ROADWAY ALIGNMENT/SHOWN IN THE ROADWAY PLANS. NOTE: WORK SHOULD BE COMPLETED IN A CONTINUOUS MANNER. SEE ICT FOR CONSTRUCTION TIME AND LIQUIDATED DAMAGES.
- PLACE FINAL PAVEMENT MARKINGS ON SOUTH ELM EUGENE -Y3- (SR-3303) FROM STATION 13+90 +/- -Y3- TO STATION 19+00 +/- -Y3- AND RAMPS, (SEE ROADWAY PLANS).

- STEP 3:** - REMOVE ALL TRAFFIC CONTROL DEVICES, PEDESTRIAN ACCOMODATIONS, SIGNING AND DETOUR ROUTE SIGNING.
- OPEN SOUTH ELM EUGENE STREET (SR-3303), -Y3- AND WESTBOUND ON & OFF RAMPS TO FINAL TRAFFIC PATTERN.

10/5/2021 4:52 PM
 V:\Asheville\Transportation\31639-03 I-5964 Div 7 I-40 Elm-Eugene\TrafficControl\CP\5964_TC_TMP-3.dgn
 User:hparrrett

Tri-Cities, TN 423-467-8401
 Knoxville, TN 865-546-5800
 Spartanburg, SC 864-574-4775
 Charleston, SC 843-974-5650
 Middlesboro, KY 606-248-6600
 Charlotte, NC 704-357-0488
 Boone, NC 828-355-9933
 Atlanta, GA 770-627-3509
 Copyright © 2006 Vaughn & Melton, Inc. All Rights Reserved

DOCUMENT NOT CONSIDERED FINAL UNLESS ALL SIGNATURES COMPLETED

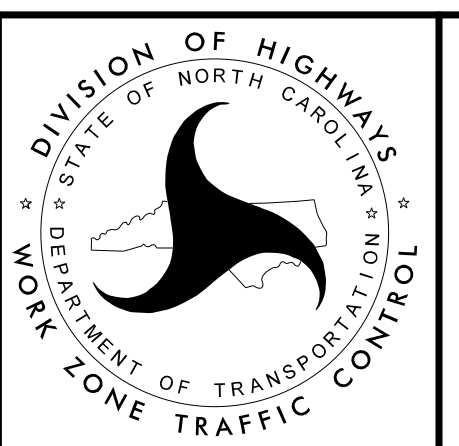
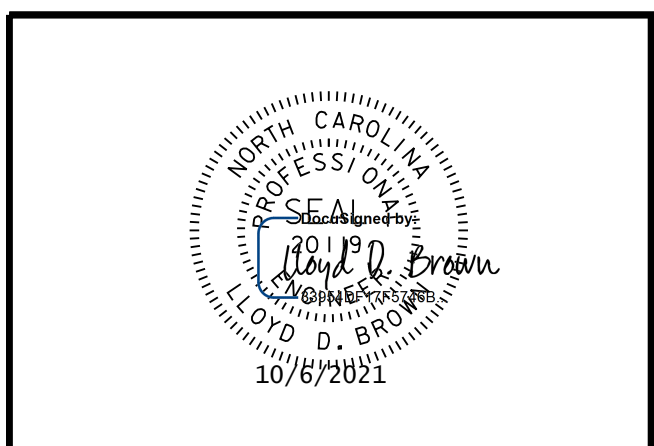

TEMPORARY TRAFFIC CONTROL DEVICES, SIGNING AND PHASING NOTES

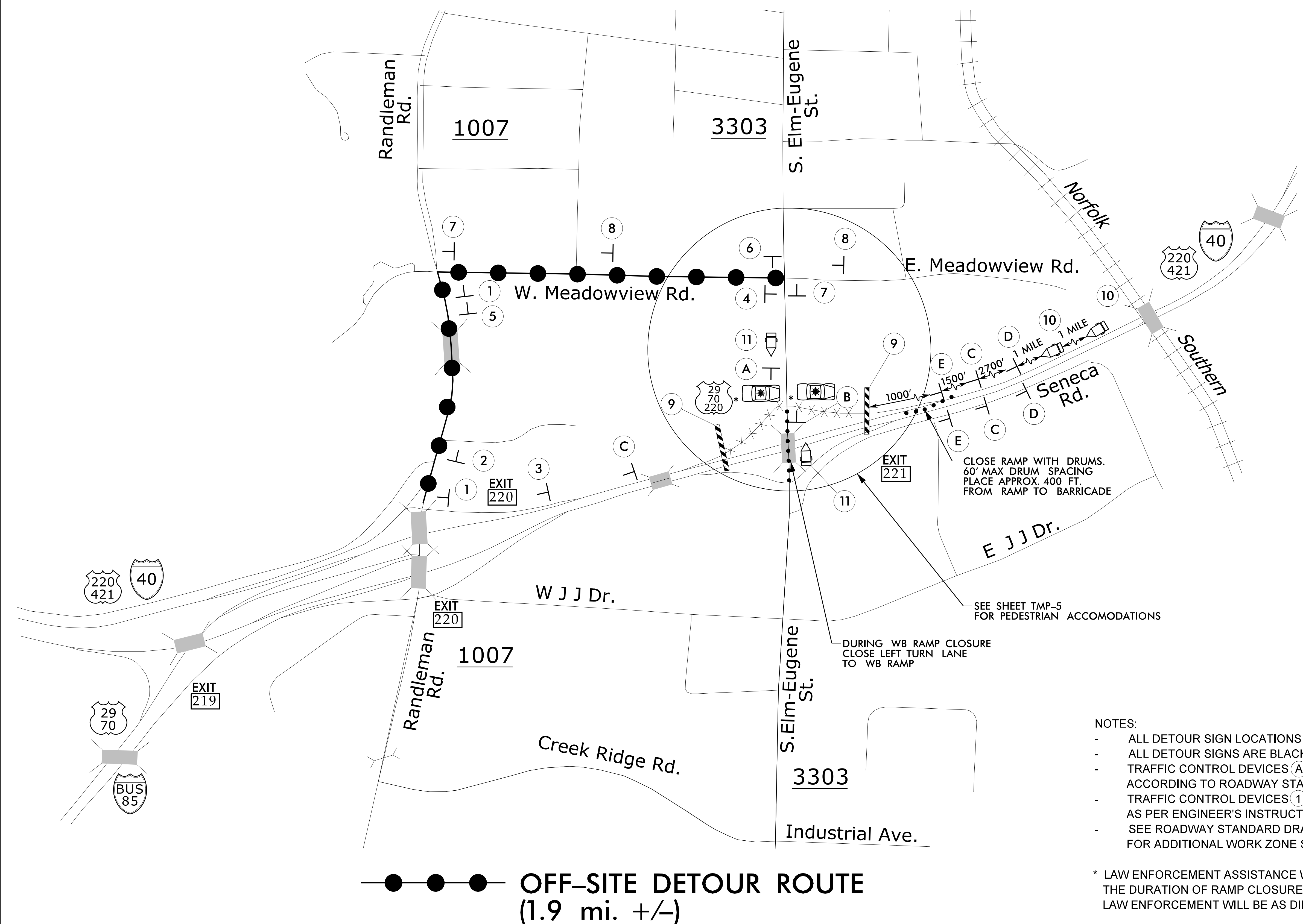
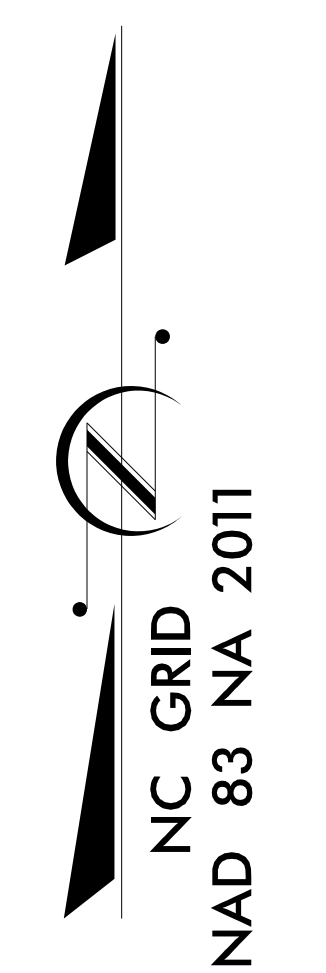

CLOSE RAMP WITH DRUMS.
60' MAX DRUM SPACING
PLACE APPROX. 400 FT.
FROM RAMP TO BARRICADE

SEE SHEET TMP-5
FOR PEDESTRIAN ACCOMODATIONS

DURING WB RAMP CLOSURE
CLOSE LEFT TURN LANE
TO WB RAMP

NOTES:

- ALL DETOUR SIGN LOCATIONS ARE APPROXIMATE.
- ALL DETOUR SIGNS ARE BLACK ON ORANGE UNLESS OTHERWISE NOTED.
- TRAFFIC CONTROL DEVICES (A) THROUGH (E) SHALL BE INSTALLED ACCORDING TO ROADWAY STANDARD DRAWING 1101.03, SHEET 1 OF 9.
- TRAFFIC CONTROL DEVICES (1) AND (11) SHALL BE INSTALLED AS PER ENGINEER'S INSTRUCTIONS, AND AS SHOWN HEREON.
- SEE ROADWAY STANDARD DRAWING NO. 1101.03, SHEET 1 OF 9 AND 2 OF 9, FOR ADDITIONAL WORK ZONE SIGNS, BARRICADES AND NOTES.

* LAW ENFORCEMENT ASSISTANCE WILL REMAIN FOR THE DURATION OF RAMP CLOSURES. THE LOCATION OF LAW ENFORCEMENT WILL BE AS DIRECTED BY THE ENGINEER.

●●● OFF-SITE DETOUR ROUTE
(1.9 mi. +/-)

7/9/2021 3:19:23 PM V:\Asheville\Transportation\31639-03 I-5964 Div 7 I-40 Elm-Eugene\TrafficControl\CPN5964_TC_TMP-4.dgn User:tcjmarrell

V&M
Vaughn & Melton
Consulting Engineers

Asheville, North Carolina
828-253-2796

Charlotte, NC 704-357-0488 Boone, NC 828-355-9933 Tri-Cities, TN 423-467-8401 Knoxville, TN 865-546-5800 Spartanburg, SC 864-574-4775 Charleston, SC 843-974-5650 Middlesboro, KY 606-248-6600 Atlanta, GA 770-627-3509

Copyright © 2006 Vaughn & Melton, Inc. All Rights Reserved

**DOCUMENT NOT CONSIDERED FINAL
UNLESS ALL SIGNATURES COMPLETED**

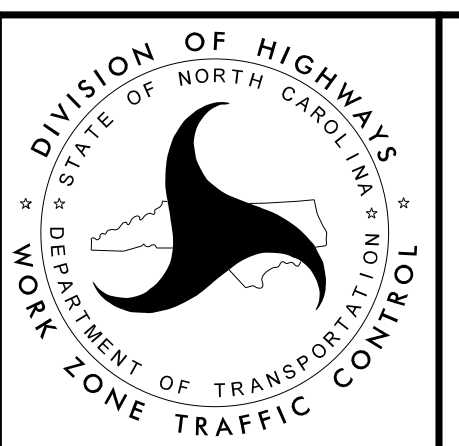
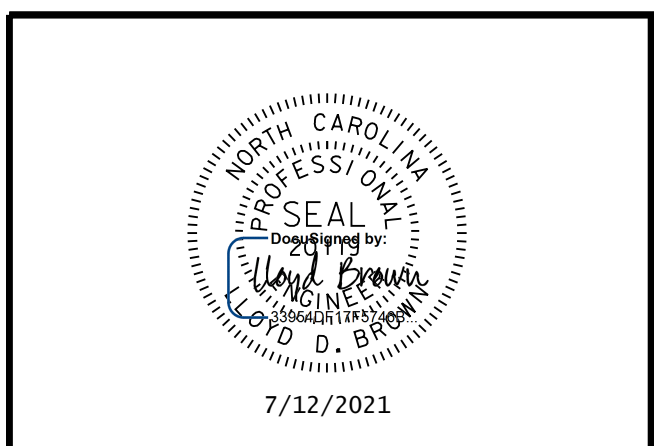

**OFF-SITE
DETOUR SIGNING
AND LANE CLOSURE**

USE FOR STEP 1 SEE SHEET TMP-4

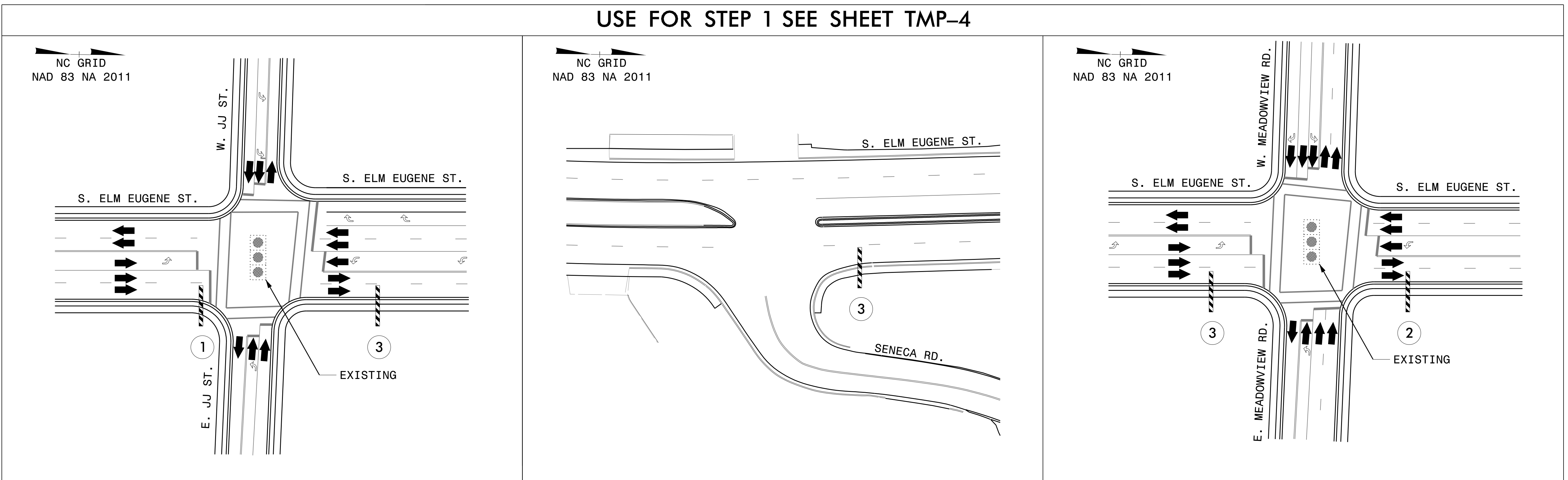

USE FOR STEP 2 SEE SHEET TMP-4

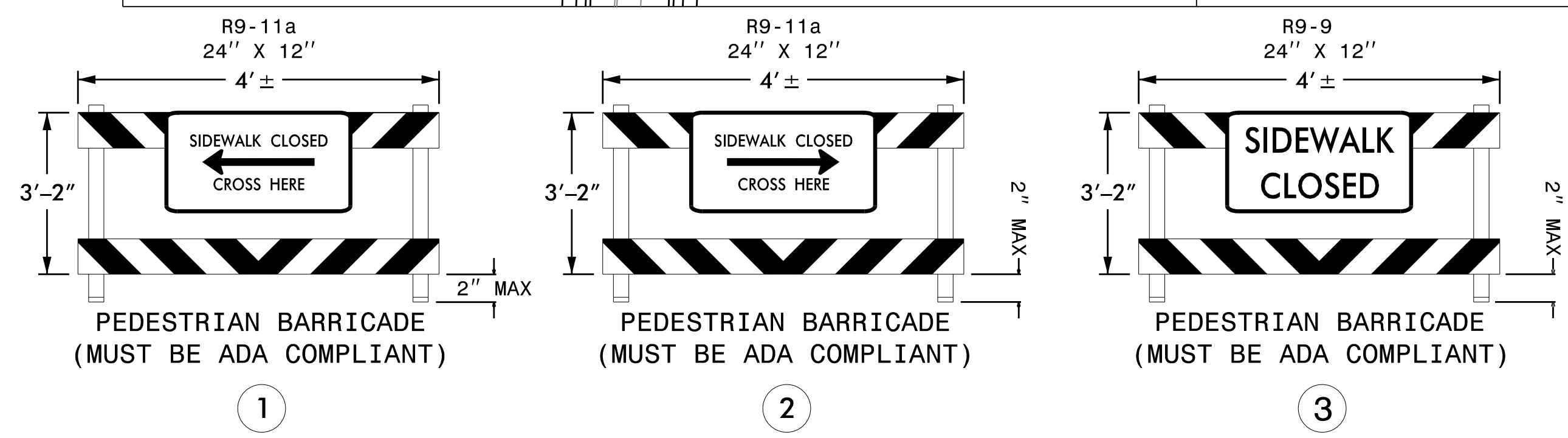
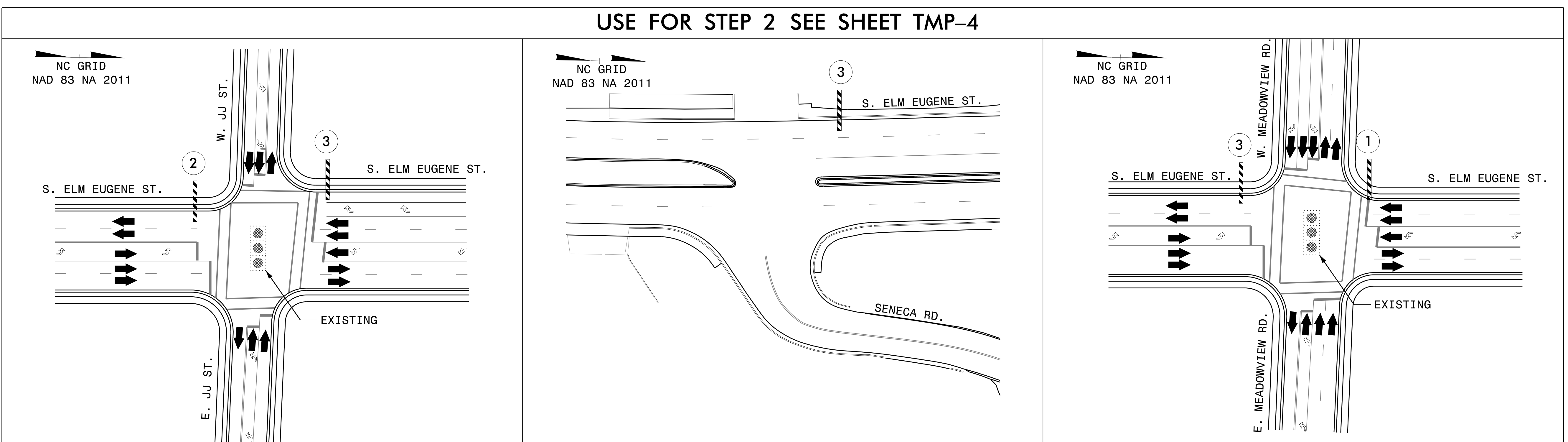

V&M
Vaughn & Melton
 Consulting Engineers
 Asheville, North Carolina
 828-253-2796

☐ Tri-Cities, TN 423-467-8401	☐ Knoxville, TN 865-546-5800	☐ Spartanburg, SC 864-574-4775
☐ Charleston, SC 843-974-5650	☐ Middlesboro, KY 606-248-6600	☐ Atlanta, GA 770-627-3509
☐ Charlotte, NC 704-357-0488	☐ Boone, NC 828-355-9933	

Copyright © 2006 Vaughn & Melton, Inc. All Rights Reserved

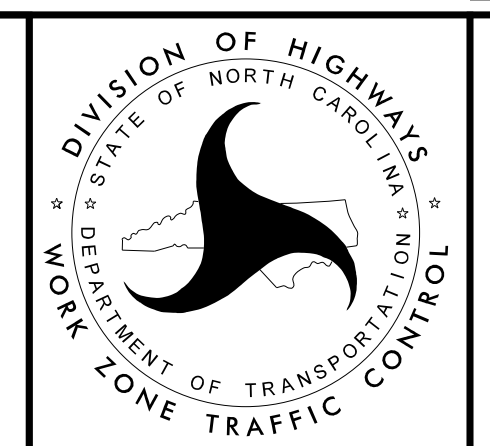
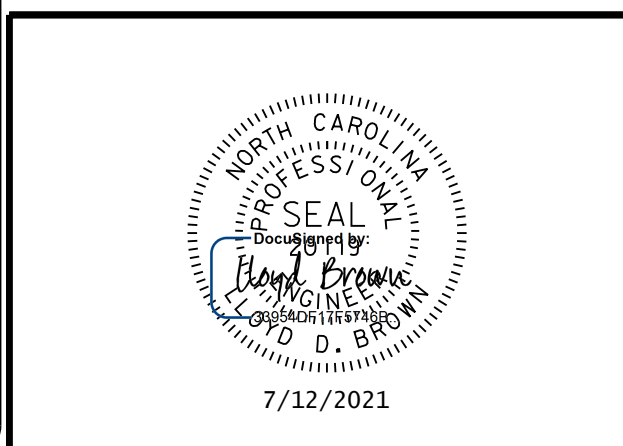

DOCUMENT NOT CONSIDERED FINAL
 UNLESS ALL SIGNATURES COMPLETED

TEMPORARY PEDESTRIAN
 DETOUR DETAIL

7/8/2021 4:25 PM
 V:\Asheville\Transportation\31639-03 I-5964 Div 7 I-40 Elm-Eugene\Traffic\TrafficControl\I-5964_TC_TMP-5.dgn
 User: tcimartell

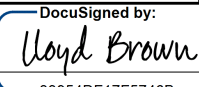
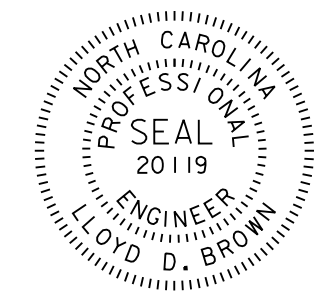
TIP NO. I - 5964	SHEET NO. PMP - 1
APPROVED:  33654DF17F5746B	
DATE: 7/12/2021	
SEAL 	
DOCUMENT NOT CONSIDERED FINAL UNLESS ALL SIGNATURES COMPLETED	

**STATE OF NORTH CAROLINA
DEPARTMENT OF TRANSPORTATION**

**PAVEMENT MARKING PLAN
GUILFORD COUNTY
DIVISION 7**

LOCATION: I-40I-85 BUS./SOUTH ELM-EUGENE INTERCHANGE IMPROVEMENTS

TIP PROJECT: I-5964

ROADWAY STANDARD DRAWING

THE FOLLOWING ROADWAY STANDARDS AS APPEAR IN "ROADWAY STANDARD DRAWINGS" - N.C. DEPARTMENT OF TRANSPORTATION - RALEIGH, N.C., DATED JANUARY 2018 ARE APPLICABLE TO THIS PROJECT AND BY REFERENCE HEREBY ARE CONSIDERED A PART OF THESE PLANS:

STD. NO.	TITLE
1205.01	PAVEMENT MARKINGS - LINE TYPES AND OFFSETS
1205.02	PAVEMENT MARKINGS - TWO-LANE AND MULTILANE ROADWAYS
1205.03	PAVEMENT MARKINGS - EXIT AND ENTRANCE RAMP
1205.04	PAVEMENT MARKINGS - INTERSECTIONS
1205.05	PAVEMENT MARKINGS - TURN LANES
1205.06	PAVEMENT MARKINGS - LANE DROPS
1205.07	PAVEMENT MARKINGS - PEDESTRIAN CROSSWALKS
1205.08	PAVEMENT MARKINGS - SYMBOLS AND WORD MESSAGES
1205.09	PAVEMENT MARKINGS - PAINTED ISLANDS

GENERAL NOTES

THE FOLLOWING GENERAL NOTES APPLY AT ALL TIMES FOR THE DURATION OF THE CONSTRUCTION PROJECT, EXCEPT WHEN OTHERWISE NOTED IN THE PLAN, OR DIRECTED BY THE ENGINEER.

- A) INSTALL PAVEMENT MARKINGS AND PAVEMENT MARKERS ON THE FINAL SURFACE AS FOLLOWS:

ROAD NAME	MARKING	MARKER
ELM-EUGENE & RAMP	THERMOPLASTIC	NONE

- B) TIE PROPOSED PAVEMENT MARKING LINES TO EXISTING PAVEMENT MARKING LINES.
 C) REMOVE/REPLACE ANY CONFLICTING/DAMAGED PAVEMENT MARKINGS AND MARKERS.
 D) UNLESS OTHERWISE SPECIFIED, HEATED-IN-PLACE THERMOPLASTIC MAY BE USED IN LIEU OF COLD APPLIED PLASTIC FOR STOP BARS, SYMBOLS, CHARACTERS AND DIAGONALS ON ASPHALT OR CONCRETE ROADWAYS. IF HEATED-IN-PLACE IS USED, IT SHALL BE PAID FOR USING THE COLD APPLIED PAY ITEM.

INDEX

SHEET NO.	DESCRIPTION
PMP - 1	PAVEMENT MARKING PLAN TITLE
PMP - 2	PAVEMENT MARKING DETAIL AND FINAL PAVEMENT MARKING SCHEDULE



Vaughn & Melton
Consulting Engineers

Asheville, North Carolina
828-253-2796

- Boone, NC 828-355-9933
- Chattanooga, TN 423-467-9400
- Knoxville, TN 865-546-5800
- Spartanburg, SC 864-574-4775
- Charleston, SC 843-974-5650
- Middlesboro, KY 606-248-6600
- Raleigh, NC 919-977-9455
- Charlotte, NC 704-357-0488
- Atlanta, GA 770-627-3550

Copyright © 2006 Vaughn & Melton, Inc. All Rights Reserved

TIP NO. I-5964	SHEET NO. PMP-2
APPROVED: <i>Lloyd Brown</i> 33964DF1F5746B	
DATE: 7/12/2021	
SEAL	
	
DOCUMENT NOT CONSIDERED FINAL UNLESS ALL SIGNATURES COMPLETED	

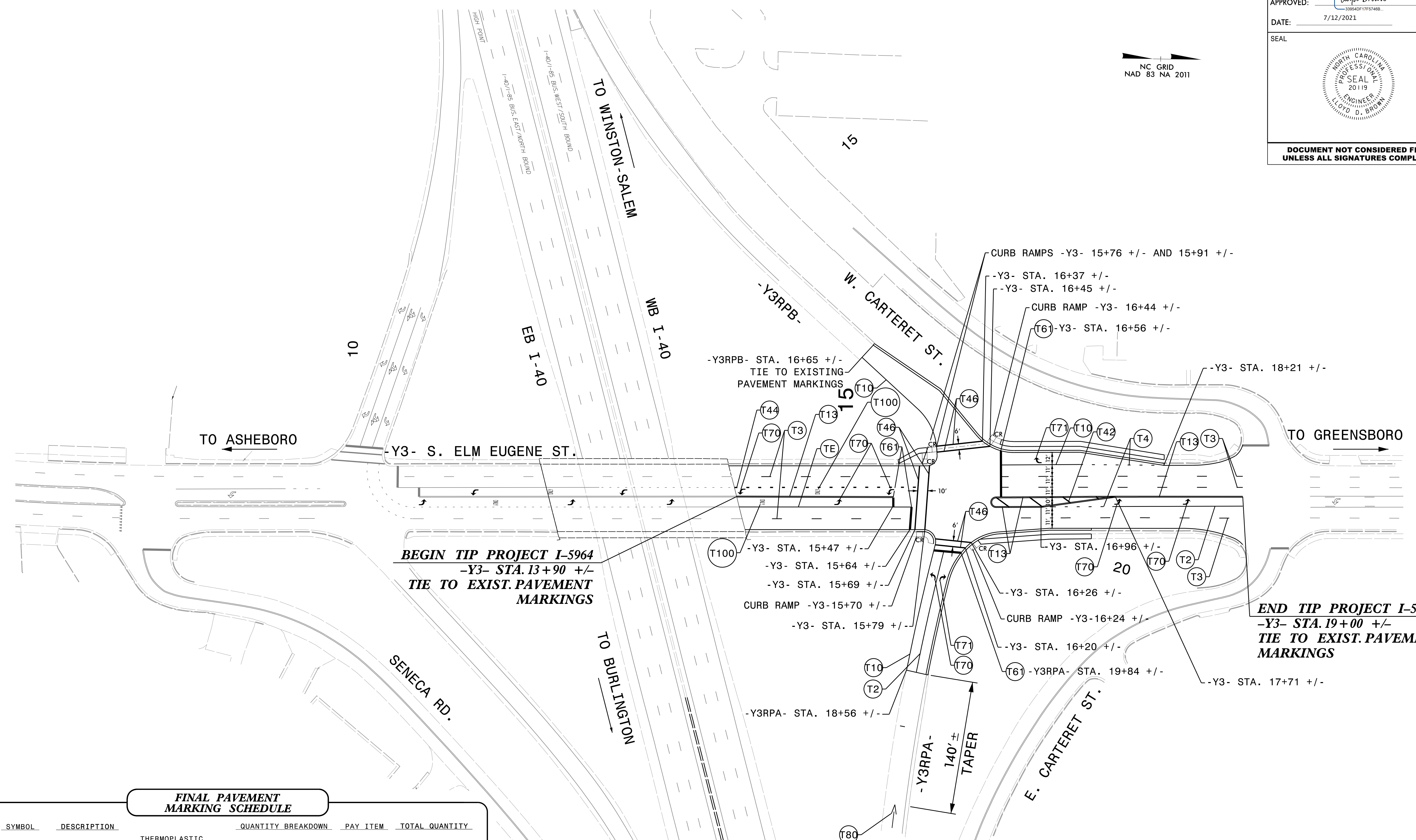
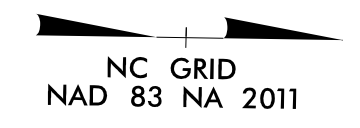

FINAL PAVEMENT MARKING SCHEDULE

SYMBOL	DESCRIPTION	QUANTITY BREAKDOWN	PAY ITEM	TOTAL QUANTITY
THERMOPLASTIC				
T2	WHITE SOLID LANE LINE (4", 90 MIL)	509 FT	4685000000-E	509 FT
T3	10FT. WHITE SKIP (4", 90 MIL)	252 FT	4685000000-E	252 FT
T4	3FT.-9FT./SP WHITE MINISKIP (4", 90 MIL)	159 FT	4685000000-E	159 FT
T10	YELLOW EDGELINE (4", 90 MIL)	260 FT	4685000000-E	260 FT
T13	YELLOW DOUBLE CENTER (4", 90 MIL)	544 FT	4685000000-E	544 FT
T42	YELLOW DIAGONAL (8", 90 MIL)	47 FT	4695000000-E	47 FT
T44	3FT.-9FT./SP WHITE MINISKIP (8", 90 MIL)	47 FT	4695000000-E	47 FT
T46	WHITE CROSSWALK LINE (8", 90 MIL)	297 FT	4695000000-E	297 FT
T61	WHITE STOPBAR (24", 90 MIL)	107 FT	4891000000-E	107 FT
T70	LEFT TURN ARROW (90 MIL)	6 EA	4725000000-E	6 EA
T71	RIGHT TURN ARROW (90 MIL)	2 EA	4725000000-E	2 EA
T80	WRONG-WAY RAMP ARROW (90 MIL)	1 EA	4725000000-E	1 EA
T100	ALPHANUMERIC CHARACTER (90 MIL)	8 EA	4720000000-E	8 EA

**PAVEMENT MARKING
DETAIL**

7/8/2021 2:44:58 PM
 V:\Asheville\Transportation\31639-03 I-5964 Div 7 I-40 Elm-Eugene\Traffic\TrafficControl\I5964_PM_PMP-2.dgn
 User: c:\imartell